

PRESSURE SWITCHES

Pressure and temperature monitoring solutions

Pressure transmitters



Thermostats



trafford

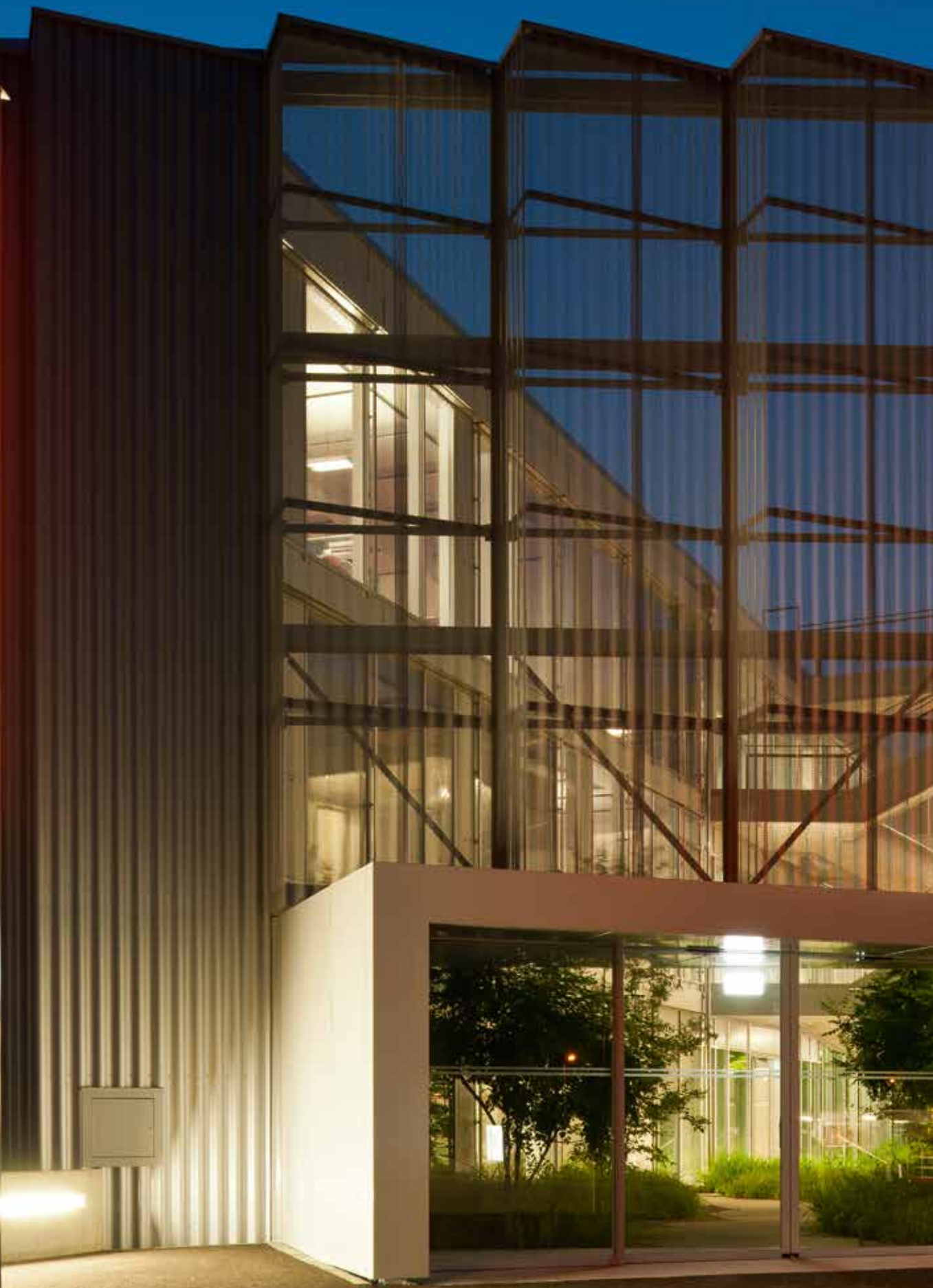

Trafag – Sensors and monitoring instruments for pressure and temperature

Trafag, a Swiss-based company founded in 1942, is supported by a broad sales and service network in over 40 countries across the world. This allows Trafag to offer customers personalised and competent advice and ensures the best possible service. High-performance development and production departments not only guarantee the fast and reliable delivery of our high-quality and high-precision products, but also ensure that customisations can be implemented in a short time.



Competent and customer-oriented

Technological competence, manufacturing expertise and customer-orientation form the three cornerstones of Trafag as a company. Trafag is a completely independent company with headquarters in Bubikon, Switzerland, and further manufacturing companies in Germany and the Czech Republic. A fifth of its employees in Switzerland are involved in the fields of research and development, production technology or applications engineering.

Application and solution-oriented

The direct availability of these resources enables Trafag to be extremely flexible in the areas of development and production as well as in its perception and implementation of customer requirements. Thanks to modular engineering, Trafag is able to efficiently adapt its standard products to the specific needs of customers and to develop special OEM solutions.

Market-oriented and always within reach

Trafag maintains an active presence in over 40 countries. A great number of customers in diverse industrial sectors such as mechanical engineering, hydraulics, engine manufacturing, shipbuilding, railway technology or high-voltage technology appreciate the cooperation offered by our technically competent customer advisory service.

Adaptable and efficient

The ability to develop and manufacture its strategically important components in-house means that Trafag can both mass-produce and manufacture on a small scale at short notice. Rigorous quality management in accordance with ISO 9001, state of the art production facilities under clean room conditions and stringently monitored production processes ensure that Trafag meets the highest quality demands.



Trafalgar
Solenoid Valve

S/N 1999999-001
Type 9M4.4279
Range 1...16 bar (1...1.6 MPa)
P-max 1 200 bar/20 MPa
250V AC 6(1)A 24V DC 3(2)A

04/13
IP65
-25T85

CE

3 2 1 P



Content

Pressure switches and accessories



Trafag's electromechanical pressure switches provide high vibration resistance and switch point precision in combination with an extremely robust and durable design. This results in switches that can be operated for decades without requiring maintenance, even under harsh conditions. Various designs with bellows, membrane and piston sensors cover a wide variety of pressure ranges, media and load profiles for many different applications. Pressostats are available with Ex- and ship approvals as well as with railway conformity.

Markets and applications	6 - 7
Pressure switches technology	8
Information on accessories	9
Overview Pressure switches	10 - 11
Information on pressure transmitters and thermostats	12
Data sheets of the pressure switches	13 - 103
Accessories	104 - 110
Terminology for pressure measurement instruments	111 - 114
Information on Ex products	115
Simple Apparatus	116
Fluid resistance guide	117 - 119
Conversion of pressure and temperature units	120 - 121
Address directory Trafag worldwide	122 - 125

Our products are at home where you are



Shipbuilding



- Propulsion
- Pumps
- Ballast water treatment
- Steering
- Separators
- Tank level

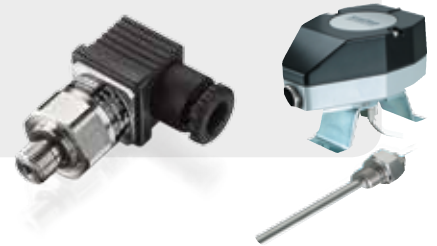

Hydraulics



- Construction machinery
- Agricultural machinery
- Injection molding machines
- Community vehicles
- Elevators



Engines



- Common rail injection
- Cooling water
- Oil pressure
- Fuel pressure
- Turbo charger



Railways

- Brake systems
- Pantograph
- Air compressors



Water treatment

- Drinking water
- Waste water
- Desalination
- Pools
- Sluice steering
- Level control



Various

- Chemical industry
- Mining
- Process technology
- Oil and gas
- Machine building industry
- HVAC

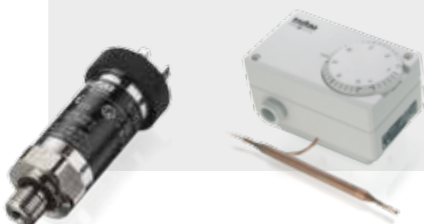

Pressure switches

Trafag's electromechanical pressure switches provide high vibration resistance and switch point precision in combination with an extremely robust and durable design. This results in switches that can be operated for decades without requiring maintenance, even under harsh conditions. Various designs with bellows, membrane and piston sensors cover a wide variety of pressure ranges, media and load profiles for many different applications. Pressostats are available with Ex- and ship approvals as well as with railway conformity.

Bellows sensors

- High switching point precision and repeatability
- Stainless steel, bronze and brass designs
- Optionally welded/soldered design for absolute impermeability
- Measure liquid, vaporous and gaseous media



Piston sensors

- Suitable for high pressure ranges
- Not sensitive to pressure surges
- Suitable for applications with many load cycles
- Ideal for hydraulic systems



Membrane sensors

- Resistant to high overpressures and not sensitive to pressure surges
- Suitable for applications with many load cycles
- Measure liquid, vaporous and gaseous media



Accessories







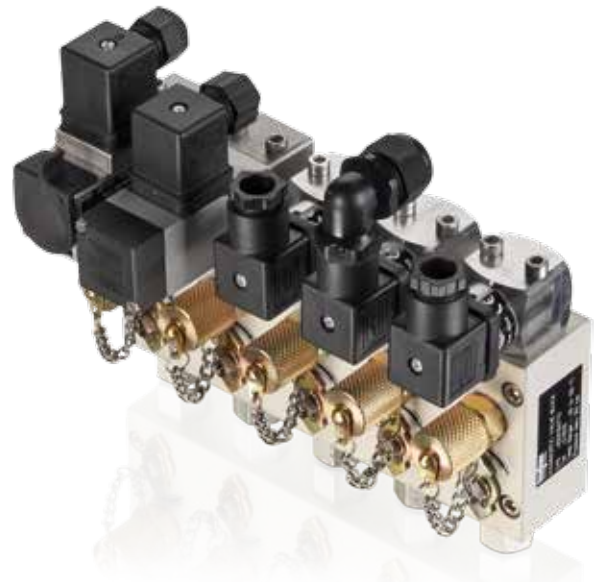



Trafag offers a wide range of original accessories which are ideally matched to our products. These include devices for monitoring or configuring transmitters such as hand pumps with precision pressure gauge or the Sensor Communicator, a handheld device which provides direct access to the calibration values of the transmitter in the Trafag ASIC. Trafag also offers a wide range of accessories meet specific application requirements and also make installation easier. They include diagnostic valve manifolds, snubbers and pressure peak damping elements for measuring pressure, or protective pipes for thermostats.

Accessories for pressure measurement instruments

- SMI Sensor Master Interface
- Sensor Communicator
- CAN2USB CANopen Configuration Tool
- DVB Diagnostic Valve Block
- Hand pump with precision manometer
- Switch amplifier
- Venting box
- Cable hanger
- Pressure peak damping element
- Snubber
- Adapters for different pressure connections
- Stop valve

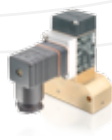

Overview pressure switches

	PST4B 9B4 	PST4K 9K4 	PST4M 9M4 	PSTD 9D0 	P/PS 900/904/912 	PV/PVF 903/907/915/940/941/942 
	page 13	page 19	page 24	page 29	page 39	page 45
						
Measuring principle	Bellow	Piston	Membrane	Bellow	Bellow	Bellow
Measuring range	-0.6 ... 3.4 to 4 ... 40 bar -8 ... 45 to 60 ... 500 psi	1 ... 10 to 40 ... 400 bar 14 ... 150 to 580 ... 5800 psi	1 ... 10 to 10 ... 100 bar 14 ... 150 to 150 ... 1500 psi	-1 ... 6 and -1 ... 8 bar	-0.9 ... 1.5 to 10 ... 100 bar 5 ... 50 to 125 ... 1500 psi	-0.9 ... 1.5 to 4 ... 40 bar 5 ... 50 to 50 ... 500 psi
Output signal	1 Floating change-over contact (SPDT)	1 Floating change-over contact (SPDT)	1 Floating change-over contact (SPDT)	1 Floating change-over contact (SPDT)	1 Floating change-over contact (SPDT)	1 Floating change-over contact (SPDT)
Pressure connections	G1/8" f, G1/4" f, M10x1.0 f	G1/8" f, G1/4" f, M10x1.0 f	G1/8" f, G1/4" f, M10x1.0 f	G1/4" f	G1/4" f, G1/2" m, 1/4"NPT f	G1/4" f, G1/2" m, 1/4" NPT f
Electrical connections	EN175301-803-A (DIN43650-A)	EN175301-803-A (DIN43650-A)	EN175301-803-A (DIN43650-A)	EN175301-803-A (DIN43650-A)	Screw terminal	Screw terminal
Switching differential	Not adjustable	Not adjustable	Not adjustable	Not adjustable	Not adjustable	Adjustable
Media temperature	-25°C ... +125°C -40°C ... +125°C	-25°C ... +125°C	0°C ... +80°C	-25°C ... +120°C	-40°C ... +150°C	-40°C ... +150°C
Ambient temperature	-25°C ... +125°C -40°C ... +125°C	-25°C ... +85°C	0°C ... +80°C	-25°C ... +85°C	-25°C ... +70°C	-25°C ... +70°C
Protection	IP65	IP65	IP65	IP65	IP65	IP65
Housing	Aluminium EN AW-6026 AlMgSiPb0.4 anodized	Aluminium EN AW-6026 AlMgSiPb0.4 anodized	Aluminium EN AW-6082 AlMgSi1 anodized	Brass CuZn39Pb3	AlSi10Mg/ Epoxy coated	AlSi10Mg/ Epoxy coated
Sealing	HNBR 75 Sh	PTFE	FKM	-	NBR	NBR
Applications	Shipbuilding Engine manufacturing Railways Machine tools	Shipbuilding Engine manufacturing Railways Machine tools Hydraulics	Shipbuilding Engine manufacturing Railways Machine tools Hydraulics	Shipbuilding Engine manufacturing Machine tools Hydraulics	Shipbuilding Engine manufacturing Railways Machine tools Hydraulics	Shipbuilding Engine manufacturing Railways Machine tools Hydraulics
Approval / conformity	ABS, BV, CCS, DNV-GL, GL, KRS, LRS, NKK, RINA, RMRS, EN60730-1/ EN60730-2-6: Typ 2.B.H	ABS, BV, CCS, DNV, GL, KRS, LRS, RINA, EN60730-1/ EN60730-2-6: Typ 2.B.H	ABS, BV, CCS, DNV, GL, KRS, LRS, RINA, EN60730-1/ EN60730-2-6: Typ 2.B.H	DNV-GL EN60730-1/ EN60730-2-6: Typ 2.B.H	ABS, BV, CCS, DNV, GL, KRS, LRS, RINA EN60730-1/ EN60730-2-6: Typ 2.B.H	ABS, BV, CCS, DNV, GL, KRS, LRS, RINA EN60730-1/ EN60730-2-6: Typ 2.B.H
Type of protection						
Data sheet	www.trafag.com/H72367	www.trafag.com/H72369	www.trafag.com/H72368	www.trafag.com/H72273	www.trafag.com/H72252	www.trafag.com/H72257
Instructions	www.trafag.com/H73367	www.trafag.com/H73367	www.trafag.com/H73367	www.trafag.com/H73273	www.trafag.com/H71261	www.trafag.com/H71261

PK 944/947	PD 920/924/932	901/902/905/906	987/988	EXP 900/904/912	EXPK 944/947/953	EXPD 920/924/932
page 51	page 57		page 63	page 73	page 78	page 84
						
Piston	Bellow	Membrane	Bellow	Bellow	Piston	Bellow
1 ... 10 to 60 ... 600 bar	-1 ... 6 to -1 ... 18 bar	30 ... 600 and 50 ... 1000 mbar	-0.3 ... 1.3 to 1 ... 10 bar	-0.9 ... 1.5 to 4 ... 40 bar	1 ... 10 to 60 ... 600 bar	-1 ... 6 to -1 ... 18 bar
1 Floating change-over contact (SPDT)	1 Floating change-over contact (SPDT)	1 Floating change-over contact (SPDT)	1 or 2 floating change- over contacts (SPDT)	1 Floating change-over contact (SPDT)	1 Floating change-over contact (SPDT)	1 Floating change-over contact (SPDT)
G1/4" f, G1/2" m	G1/4" f, G1/8" f, G1/2" m	G1/4" f, G1/2" m	G1/4" m	G1/4" f, G1/2" m	G1/4" f, G1/2" m	G1/4" f, G1/8" f, G1/2" m
Screw terminal	Screw terminal	Screw terminal	Blade connector	Screw terminal	Screw terminal	Screw terminal
Not adjustable	Not adjustable	Not adjustable	Not adjustable	Not adjustable	Not adjustable	Not adjustable
NBR: -30°C ... +100°C FKM: -15°C ... +150°C	-40°C ... +150°C	-40°C ... +150°C	-25°C ... +80°C	-40°C ... +150°C	NBR: -30°C ... +100°C FKM: -15°C ... +150°C	-50°C ... +150°C
-20°C ... +70°C	-25°C ... +70°C	-25°C ... +70°C	-25°C ... +70°C	-50°C ... +65°C	-50°C ... +65°C	-50°C ... +65°C
IP65	IP65	IP65	IP40 (Microswitch IP67)	IP66	IP66	IP66
AlSi10Mg/ Epoxy coated	AlSi10Mg/ Epoxy coated	AlSi10Mg/ Epoxy coated	PBTP, Crastin	AlSi10Mg/ Epoxy coated Accessory O6: 1.4301 (AISI 304)	AlSi10Mg/ Epoxy coated Accessory O6: 1.4301 (AISI 304)	AlSi10Mg/ Epoxy coated
NBR/FKM	NBR	NBR	-	NBR	NBR / FKM	NBR
Shipbuilding Engine manufacturing Railways Machine tools Hydraulics	Shipbuilding Engine manufacturing Railways Machine tools Hydraulics	Machine tools HVAC	Machine tools Medium voltage switchgear	☉ II 2 G / D	☉ II 2 G / D	☉ II 2 G / D
ABS, BV, CCS, DNV, GL, KRS, LRS, RINA EN60730-1/ EN60730-2-6: Typ 2.B.H	ABS, BV, CCS, DNV-GL, KRS, LRS, RINA EN60730-1/ EN60730-2-6: Typ 2.B.H	EN60730-1/ EN60730-2-6: Typ 2.B.H	EN60730-1/ EN60730-2-6: Typ 2.B.H	SEV 15 ATEX 0157 X IECEx SEV 17.0013X	SEV 15 ATEX 0157 X IECEx SEV 17.0013X	SEV 15 ATEX 0157 X IECEx SEV 17.0013X
				Areas with gaz explosion hazards: II 2 G Ex db eb IIC T6 Gb; Areas with dust explosion hazards: II 2 D Ex tb IIIC T80°C Db	Areas with gas explosion hazards: II 2 G Ex db eb IIC T6 Gb; Areas with dust explosion hazards: II 2 D Ex tb IIIC T80°C Db	Areas with gas explosion hazards: II 2 G Ex db eb IIC T6 Gb; Areas with dust explosion hazards: II 2 D Ex tb IIIC T80°C Db
www.trafag.com/H72259	www.trafag.com/H72253	www.trafag.com/H72269	www.trafag.com/H72272	www.trafag.com/H72263	www.trafag.com/H72270	www.trafag.com/H72256
www.trafag.com/H71261	www.trafag.com/H73256		www.trafag.com/H73272	www.trafag.com/H73171	www.trafag.com/H73171	www.trafag.com/H73171

Pressure and temperature measuring instruments

Pressure transmitters



Trafag pressure transmitters and electronic pressure switches are used for measuring and evaluating pressure. Over the decades, they have proven themselves in a multitude of demanding applications in harsh environments. Superior technology and precise manufacturing ensure that the transmitters work perfectly, especially in areas where high requirements are placed on long-term stability, vibration resistance, electromagnetic compatibility, shock resistance or temperature insensitivity. Trafag pressure transmitters and electronic pressure switches are available in many different designs to suit pressure and electrical connections, measuring procedures, electrical output signals. They are available with Ex- and ship approvals as well as with railway conformity.

Pressure transmitters



Thermostats

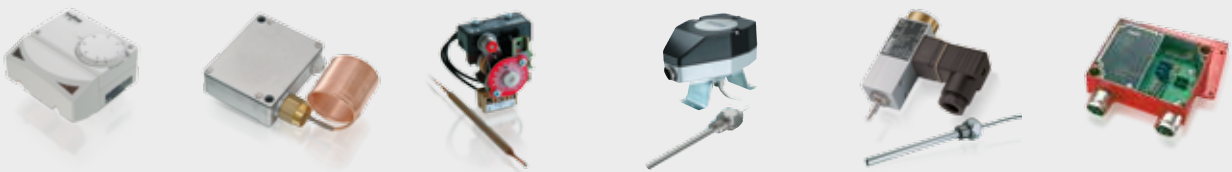

For 70 years Trafag thermostats have proven their robustness in order to withstand the most adverse environmental conditions. Industry usage ranges from air conditioning applications to engine and ship manufacturing and even to offshore oil and gas platform production. The appeal of Trafag thermostats lies in their high switching point precision even after decades of operation under harsh conditions without maintenance. Various sensor and casing designs cover a wide range of temperatures and possible applications. Thermostats are available with Ex- and ship approvals as well as with railway conformity.

Thermostats



PICOSTAT PRESSURE SWITCH

Swiss based Trafag is a leading international supplier of high quality sensors and monitoring instruments for measurement of pressure and temperature. The 9B4 of the Picostat series is based on our long lasting experience in the shipbuilding and railway sector. This further improved version offers high vibration resistance within a compact body and is suitable for a wide temperature range.



Applications

- Shipbuilding
- Engine manufacturing
- Railways
- Machine tools











Features

- Improved vibration resistance
- Compact design
- Rugged housing
- Protection IP65
- Any mounting position possible

Technical Data			
Measuring principle	Bellow	Repeatability	± 0.5 % FS typ.
Measuring range	-0.6 ... 3.4 to 4 ... 40 bar -8 ... 45 to 60 ... 500 psi	Media temperature	Standard: -25°C ... +125°C with sensor 789/790/791: -40°C ... +125°C
Output signal	1 Floating change-over contact (SPDT)	Ambient temperature	Standard: -25°C ... +125°C with sensor 789/790/791: -40°C ... +125°C
Switching differential	Not adjustable	Approval / conformity	ABS, BV, CCS, DNV-GL, GL, KRS, LRS, NKK, RINA, RMRS, EN60730-1/ EN60730-2-6: Typ 2.B.H

Subject to change

Ordering information/type code

		9B4 .	XX	XX	XXX	XX	XX
Microswitch	Standard ¹⁾		42				
	Standard  ¹⁾		33				
	Gold plated contacts ¹⁾		84				
Range	Range [bar]	Over pressure [bar]		Range [psi]	Over pressure [psi]		
	-0.6 ... 3.4	12	74	-8 ... 45	174		G4
	0 ... 4	12	76	0 ... 50	174		G6
	0 ... 6	12	77	0 ... 100	174		G7
	1 ... 10	24	78	14 ... 150	348		G8
	1 ... 16	24	79	14 ... 250	348		G9
	2 ... 25	40	80	30 ... 400	580		H0
	4 ... 40	50	81	60 ... 500	725		H1
Sensor	Sensor material	Sensor housing material		Range			
	Bronze bellow (CuSn6)  ²⁾	Aluminium EN AW-6026 AlMgSiPb0.4 anodized		74			769
	Bronze bellow (CuSn6)  ²⁾	Aluminium EN AW-6026 AlMgSiPb0.4 anodized		76, 77			770
	Bronze bellow (CuSn6)  ²⁾	Aluminium EN AW-6026 AlMgSiPb0.4 anodized		78, 79			771
	Bronze bellow (CuSn6)  ²⁾	Aluminium EN AW-6026 AlMgSiPb0.4 anodized		80, 81			772
	Bronze bellow (CuSn6)  ^{3) 4)}	Brass (CuZn39Pb3)		74			789
	Bronze bellow (CuSn6)  ^{3) 4)}	Brass (CuZn39Pb3)		76, 77			790
	Bronze bellow (CuSn6)  ^{3) 4)}	Brass (CuZn39Pb3)		78, 79			791
	Bellows stainless steel (1.4404/AISI316L) ⁴⁾	Stainless steel		76, 77			753
Bellows stainless steel (1.4404/AISI316L) ⁴⁾	Stainless steel		78, 79			754	
Pressure connection	G1/8" female						02
	G1/4" female						04
	M10x1 female ⁵⁾						03
Accessories	Flange with O-Ring ⁴⁾						11
	Female electrical connector EN 175301-803-A (DIN43650-A)						46
	Welsh plug G1/4"						74
	Fixing set						V3
	Covering cap						15
	Lead seal (manipulation protection)						16
	Switch point adjustment on customers request						
	Please indicate when ordering:						
	- Switchpoint including measurement unit (kPa, bar, MPa, psi, abs. or rel.)						88
	- Increasing or decreasing						
Switch point scale						98	
Damping elements and snubber see data sheet H72258							

¹⁾ Switching differential not adjustable

²⁾ Media contacting O-Ring

³⁾ O-Ring not media contacting

⁴⁾ Only with pressure connection 04 (G1/4") others upon request

⁵⁾ Please ask us

Standard products (extra short lead time)

Product No.	Type Code	Pressure range [bar]	Over pressure max. [bar]	Switching differential [bar]
PST4B3.44	9B4 4274 769 04 0000 0000 15 46 V3	-0.6 ... 3.4	12	0.2 ± 0.1 (fixed)
PST4B64	9B4 4277 770 04 0000 0000 15 46 V3	0 ... 6	12	0.2 ± 0.1 (fixed)
PST4B164	9B4 4279 771 04 0000 0000 15 46 V3	1 ... 16	24	0.4 ± 0.2 (fixed)
PST4B254	9B4 4280 772 04 0000 0000 15 46 V3	2 ... 25	40	1.0 ± 0.6 (fixed)
PST4B404	9B4 4281 772 04 0000 0000 15 46 V3	4 ... 40	50	1.2 ± 0.8 (fixed)
PST4B3.4F4	9B4 4274 769 04 0000 0000 11 15 46 74 V3	-0.6 ... 3.4	12	0.2 ± 0.1 (fixed)
PST4B6F4	9B4 4277 770 04 0000 0000 11 15 46 74 V3	0 ... 6	12	0.2 ± 0.1 (fixed)
PST4B16F4	9B4 4279 771 04 0000 0000 11 15 46 74 V3	1 ... 16	24	0.4 ± 0.2 (fixed)
PST4B25F4	9B4 4280 772 04 0000 0000 11 15 46 74 V3	2 ... 25	40	1.0 ± 0.6 (fixed)
PST4B40F4	9B4 4281 772 04 0000 0000 11 15 46 74 V3	4 ... 40	50	1.2 ± 0.8 (fixed)
PST4B6S4	9B4 4277 753 04 0000 0000 15 46 V3	0 ... 6	12	0.2 ± 0.1 (fixed)
PST4B16S4	9B4 4279 754 04 0000 0000 15 46 V3	1 ... 16	24	0.4 ± 0.2 (fixed)

Specifications		
Accuracy	Repeatability	± 0.5 % FS typ.
	Switching differential	See table
	Adjustment range switchpoint ²⁾	10 % ... 90 % FS
	Temperature dependence switching point	-25°C ... +125°C: ca. -0.1% FS/°C typ. < -25°C: ca. -0.25% FS/°C typ.
Environmental conditions	Ambient temperature	Standard: -25°C ... +125°C with sensor 789/790/791: -40°C ... +125°C
	Media temperature	Standard: -25°C ... +125°C with sensor 789/790/791: -40°C ... +125°C
	Storage temperature	Standard: -30°C ... +125°C with sensor 789/790/791: -45°C ... +125°C
	Protection ¹⁾	IP65
	Humidity	Max. 95 % relative
	Vibration	Switch: IEC/EN 60068-2-6 10...59 Hz: ±0.75 mm Ampl. 59...500 Hz: 5 g
	Shock	50 g / 3 ms
Mechanical Data	Sensor	See ordering information
	Housing	Aluminium EN AW-6026 AlMgSiPb0.4 anodized
	Sealing	HNBR 75 Sh
	Housing seal	EPDM 75 Sh
	Male electrical plug	Polyamide (PA)
	Mounting torque	G 1/4": M _A = 32 ... 40 Nm
	Installation	any position
	Weight	~ 160 g
Microswitch	Rating	See table
	Resistance of insulation	500 VDC > 10 MΩ
	Dielectric strength	>1.5 kV AC/60 s terminal ground >500 VAC/60 s via open contacts
Electrical connection	Electrical connections	EN175301-803-A (DIN43650-A)
	Female electrical connector	Cable-Ø: 4 ... 9 mm Terminal screw: 4 x 0.5...1.5 mm ²

¹⁾ Provided female connector is mounted according to instructions

²⁾ Other adjustment ranges upon request

Dimensions

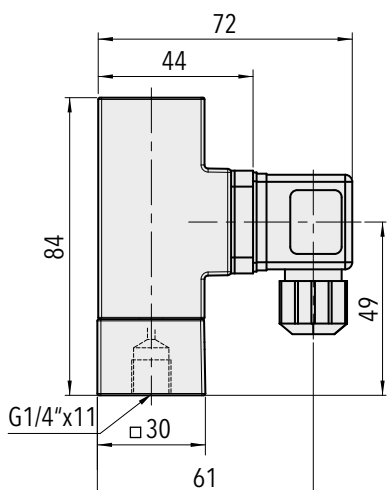

9B4.XXXX.7XX.04.46.V3

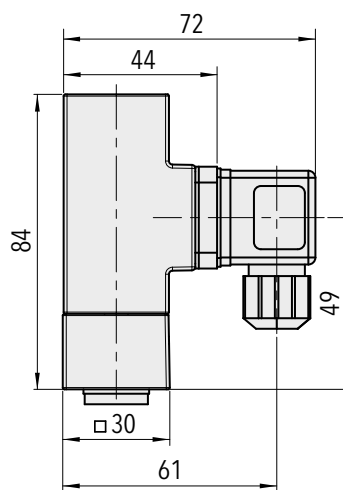
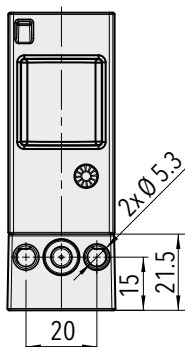

9B4.XXXX.7XX.04.11.46.74.V3

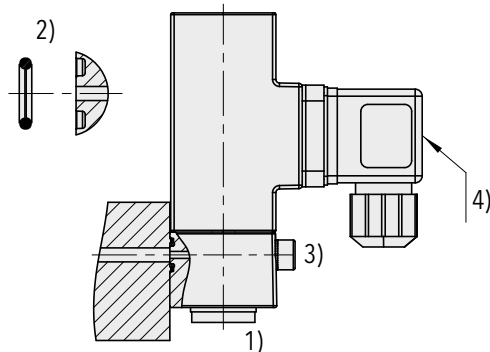
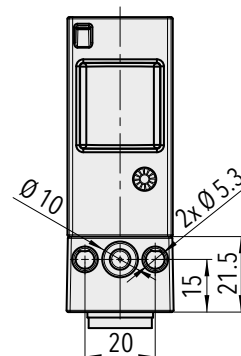

9B4.XXXX.XXX.XX.11

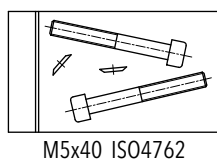

9B4.XXXX.XXX.XX.V3

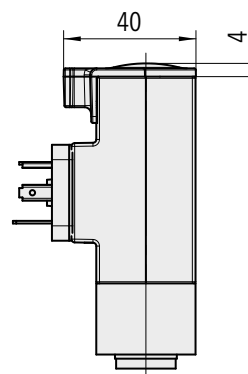

9B4.XXXX.XXX.XX.15

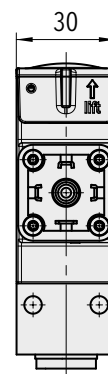

- 1) Torque: G 1/4": $M_A = 32 \dots 40 \text{ Nm}$
- 2) O-Ring: $\varnothing 6.75 \times 1.78$ NBR 90 Sh
- 3) Fixing screw: M5; property class: 8.8; torque: $4.5 \dots 6 \text{ Nm}$
- 4) Torque connector center screw: max. 0.4 Nm

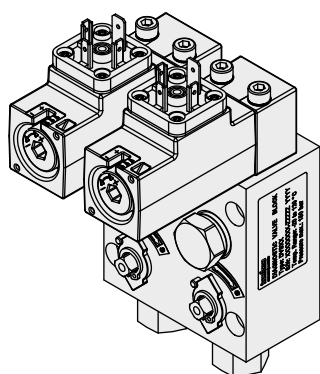

Diagnostic Valve Bloc (DVB)
see specification sheet H72361

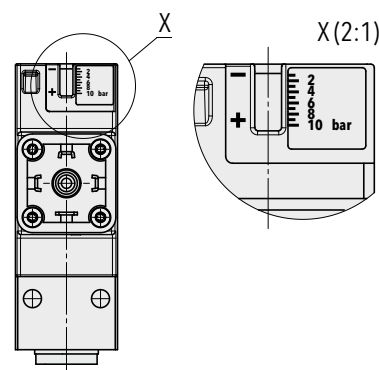

9B4.XXXX.XXX.XX.98

Switching differential typ. @ 25°C

Measuring range	[bar]	-0.6 ... 3.4	0 ... 4	0 ... 6	1 ... 10	1 ... 16	2 ... 25	4 ... 40
bellows sensor	[psi]	-8 ... 45	0 ... 50	0 ... 100	14 ... 150	14 ... 250	30 ... 400	60 ... 500
Microswitch 42/84/33:	[bar]	0.2 ± 0.1	0.2 ± 0.1	0.2 ± 0.1	0.4 ± 0.2	0.4 ± 0.2	1.0 ± 0.6	1.2 ± 0.8
Switching differential not adjustable	[psi]	4.5	4.5	4.5	9	9	22	26

Electrical data switch

Type	Features	Rating	
		Resistive Load (Inductive Load)	
		AC	DC
42/33 (Standard)	Silver contacts	250 V, 6 (1) A	220 V, 0.25 (0.1) A 110 V, 0.5 (0.2) A 60 V, 1(0.5) A 24 V, 3 (2) A 12 V, 6 (6) A
84	Gold plated contacts, suitable for intrinsically safe control circuits	max. 30 V, 0.1 (0.1) A min. 5 V, 5 mA	

Electrical connection

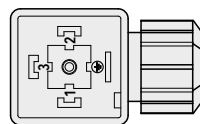
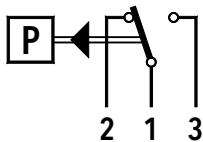

EN175301-803-A

Additional information

Documents	Data sheet	www.trafag.com/H72367
	Instructions	www.trafag.com/H73367
	Flyer	www.trafag.com/H70655

PICOSTAT PRESSURE SWITCH

Swiss based Trafag is a leading international supplier of high quality sensors and monitoring instruments for measurement of pressure and temperature. The 9K4 of the Picostat series is based on our long lasting experience in the shipbuilding and railway sector. This further improved version offers high vibration resistance within a compact body and is suitable for a wide temperature range.



Applications

- Shipbuilding
- Engine manufacturing
- Railways
- Machine tools
- Hydraulics



Features

- Compact design
- Rugged housing
- Protection IP65 (with plug connector)
- Any mounting position possible

Technical Data			
Measuring principle	Piston	Repeatability	± 1.0 % FS typ.
Measuring range	1 ... 10 to 40 ... 400 bar 14 ... 150 to 580 ... 5800 psi	Media temperature	-25°C ... +125°C
Output signal	1 Floating change-over contact (SPDT)	Ambient temperature	-25°C ... +85°C
Switching differential	Not adjustable	Approval / conformity	ABS, BV, CCS, DNV, GL, KRS, LRS, RINA, EN60730-1/ EN60730-2-6: Typ 2.B.H

Subject to change

Ordering information/type code

		9K4 .	XX	XX	XXX	XX	XX
Microswitch	Standard ¹⁾		42				
	Standard  ¹⁾		33				
	Gold plated contacts ¹⁾		84				
Range	Range [bar]	Over pressure [bar]		Range [psi]	Over pressure [psi]		
	1 ... 10	100	78	14 ... 150	1450	G8	
	1 ... 16	100	79	14 ... 250	1450	G9	
	2 ... 25	100	80	30 ... 400	1450	H0	
	4 ... 40	100	81	60 ... 500	1450	H1	
	6 ... 60	200	82	85 ... 850	2900	H2	
	10 ... 100	200	83	150 ... 1500	2900	H3	
	16 ... 160	400	84	250 ... 2500	5800	H4	
	25 ... 250	400	85	350 ... 3500	5800	H5	
	40 ... 400	600	86	580 ... 5800	8700	H6	
Sensor	Sensor material	Sensor housing material		Range			
	Piston 1.4035, sealing PTFE ²⁾	Aluminium EN AW-6026 AlMgSiPb0.4 anodized		78, 79		756	
	Piston 1.4035, sealing PTFE ²⁾	Aluminium EN AW-6026 AlMgSiPb0.4 anodized		80, 81		757	
	Piston 1.4035, sealing PTFE	Aluminium EN AW-6026 AlMgSiPb0.4 anodized		82, 83		758	
	Piston 1.4035, sealing PTFE	Aluminium EN AW-6026 AlMgSiPb0.4 anodized		84, 85, 86		759	
Pressure connection	G1/8" female						02
	G1/4" female						04
	M10x1 female ²⁾						03
Accessories	Flange with O-Ring ³⁾						11
	Female electrical connector EN 175301-803-A (DIN43650-A)						46
	Welsh plug G1/4"						74
	Fixing set						V3
	Covering cap						15
	Lead seal (manipulation protection)						16
	Switch point adjustment on customers request						
	Please indicate when ordering:						
	- Switchpoint including measurement unit (kPa, bar, MPa, psi, abs. or rel.)						88
	- Increasing or decreasing						
Damping elements and snubber see data sheet H72258							

¹⁾ Switching differential not adjustable

²⁾ Please ask us

³⁾ Only with pressure connection 04 (G1/4"), others upon request

Standard products (extra short lead time)

Product No.	Type Code	Pressure range [bar]	Over pressure max. [bar]	Switching differential [bar]
PST4K164	9K4 4279 756 04 0000 0000 15 46 V3	1 ... 16	100	0.4 ... 2.4 (fixed)
PST4K404	9K4 4281 757 04 0000 0000 15 46 V3	4 ... 40	100	1 ... 6 (fixed)
PST4K1004	9K4 4283 758 04 0000 0000 15 46 V3	10 ... 100	200	5 ... 15 (fixed)
PST4K2504	9K4 4285 759 04 0000 0000 15 46 V3	25 ... 250	400	12 ... 40 (fixed)
PST4K4004	9K4 4286 759 04 0000 0000 15 46 V3	40 ... 400	600	15 ... 50 (fixed)
PST4K16F4	9K4 4279 756 04 0000 0000 11 15 46 74 V3	1 ... 16	100	0.4 ... 2.4 (fixed)
PST4K40F4	9K4 4281 757 04 0000 0000 11 15 46 74 V3	4 ... 40	100	1 ... 6 (fixed)
PST4K100F4	9K4 4283 758 04 0000 0000 11 15 46 74 V3	10 ... 100	200	5 ... 15 (fixed)
PST4K250F4	9K4 4285 759 04 0000 0000 11 15 46 74 V3	25 ... 250	400	12 ... 40 (fixed)
PST4K400F4	9K4 4286 759 04 0000 0000 11 15 46 74 V3	40 ... 400	600	15 ... 50 (fixed)

Specifications		
Accuracy	Repeatability	± 1.0 % FS typ.
	Switching differential	See table
	Adjustment range switchpoint ²⁾	10 % ... 90 % FS
	Temperature dependence switching point	approx. + 0.1% FS/°C typ.
Environmental conditions	Ambient temperature	-25°C ... +85°C
	Media temperature	-25°C ... +125°C
	Storage temperature	-40°C ... +85°C
	Protection ¹⁾	IP65
	Humidity	Max. 95 % relative
	Vibration	Switch IEC/EN 60068-2-6: 10...59 Hz: ±0.75 mm Ampl. 59...500 Hz: 5 g
	Shock	50 g / 3 ms
Mechanical Data	Sensor	See ordering information
	Housing	Aluminium EN AW-6026 AlMgSiPb0.4 anodized
	Sealing	PTFE
	Housing seal	EPDM 75 Sh
	Male electrical plug	Polyamide (PA)
	Mounting torque	G 1/4": M _A = 32 ... 40 Nm
	Installation	any position
	Weight	~ 200 g
Microswitch	Rating	See table
	Resistance of insulation	500 VDC > 10 MΩ
	Dielectric strength	(IEC/EN 60730-1) >1.5 kV AC/60 s terminal ground >500 VAC/60 s via open contacts
Electrical connection	Electrical connections	EN175301-803-A (DIN43650-A)
	Female electrical connector	Cable-Ø: 4...9 mm Terminal screw: 4 x 0.5...1.5 mm ²

¹⁾ Provided female connector is mounted according to instructions

²⁾ Other adjustment ranges upon request

Dimensions

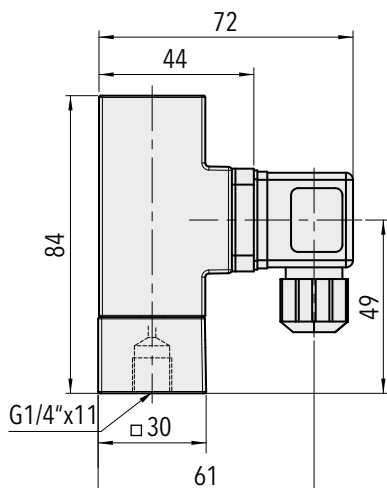

9K4.XXXX.7XX.04.46.V3

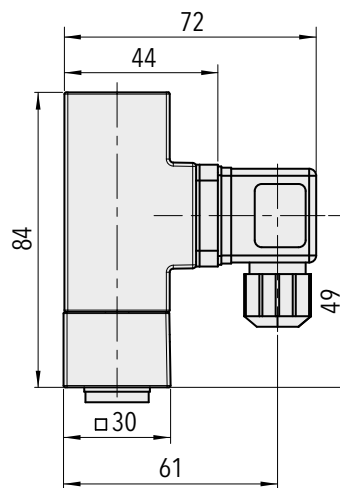
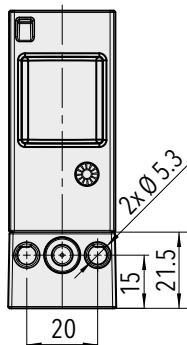

9K4.XXXX.7XX.04.11.46.74.V3

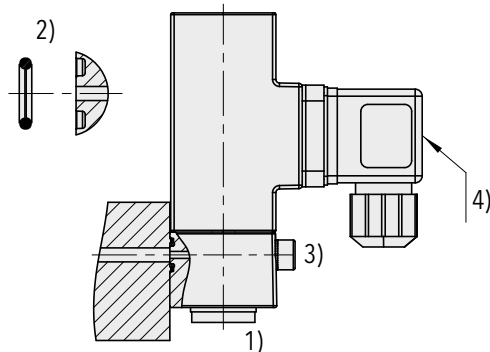
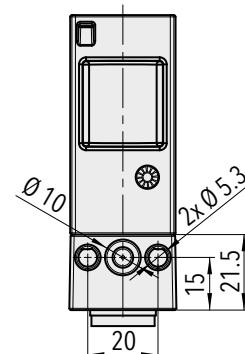

9K4.XXXX.XXX.XX.11

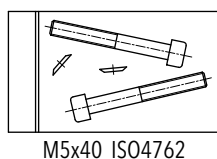

9K4.XXXX.XXX.XX.V3

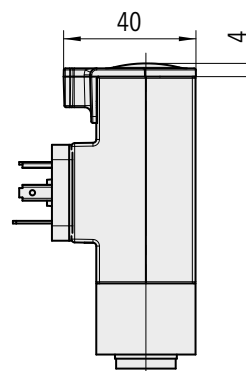

9K4.XXXX.XXX.XX.15

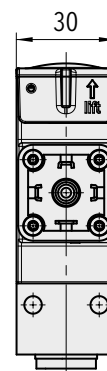

- 1) Torque: G 1/4": $M_A = 32 \dots 40 \text{ Nm}$
- 2) O-Ring: $\varnothing 6.75 \times 1.78 \text{ NBR 90 Sh}$
- 3) Fixing screw: M5; property class: 8.8; torque: $4.5 \dots 6 \text{ Nm}$
- 4) Torque connector center screw: max. 0.4 Nm

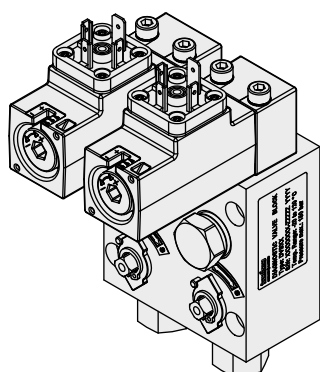

Diagnostic Valve Bloc (DVB)
see specification sheet H72361

Switching differential typ. @ 25°C

Measuring range piston sensor	[bar]	1 ... 10	1 ... 16	2 ... 25	4 ... 40	6 ... 60
	[psi]	14 ... 150	14 ... 250	30 ... 400	60 ... 500	85 ... 850
Microswitch 42/84/33: Switching differential not adjustable	[bar]	0.4 ... 2.4	0.4 ... 2.4	1 ... 6	1 ... 6	5 ... 15
	[psi]	6 ... 35	6 ... 35	14.5 ... 88	14.5 ... 88	73 ... 218
Measuring range piston sensor	[bar]	10 ... 100	16 ... 160	25 ... 250	40 ... 400	
	[psi]	150 ... 1500	250 ... 2500	350 ... 3500	580 ... 5800	
Microswitch 42/84/33: Switching differential not adjustable	[bar]	5 ... 15	12 ... 40	12 ... 40	15 ... 50	
	[psi]	73 ... 218	174 ... 580	174 ... 580	218 ... 725	

Electrical data switch

Type	Features	Rating	
		Resistive Load (Inductive Load)	
		AC	DC
42/33 (Standard)	Silver contacts	250 V, 6 (1) A	220 V, 0.25 (0.1) A 110 V, 0.5 (0.2) A 60 V, 1 (0.5) A 24 V, 3 (2) A 12 V, 6 (6) A
84	Gold plated contacts, suitable for intrinsically safe control circuits	max. 30 V, 0.1 (0.1) A min. 5 V, 5 mA	

Electrical Connection

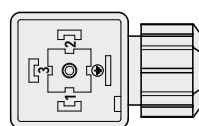
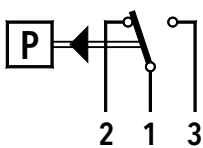

EN175301-803-A

Additional information

Documents	Data sheet	www.trafag.com/H72369
	Instructions	www.trafag.com/H73367
	Flyer	www.trafag.com/H70667

PICOSTAT PRESSURE SWITCH

Swiss based Trafag is a leading international supplier of high quality sensors and monitoring instruments for measurement of pressure and temperature. The 9M4 of the Picostat series is based on our long lasting experience in the shipbuilding and railway sector. This further improved version offers high vibration resistance within a compact body and is suitable for a wide temperature range.



Applications

- Shipbuilding
- Engine manufacturing
- Railways
- Machine tools
- Hydraulics



Features

- Compact design
- Rugged housing
- Protection IP65
- Any mounting position possible

Technical Data			
Measuring principle	Membrane	Repeatability	± 2.0 % FS typ.
Measuring range	1 ... 10 to 10 ... 100 bar 14 ... 150 to 150 ... 1500 psi	Media temperature	0°C ... +80°C
Output signal	1 Floating change-over contact (SPDT)	Ambient temperature	0°C ... +80°C
Switching differential	Not adjustable	Approval / conformity	ABS, BV, CCS, DNV, GL, KRS, LRS, RINA, EN60730-1/ EN60730-2-6: Typ 2.B.H

Subject to change

Ordering information/type code

				9M4 .	XX	XX	XXX	XX	XX
Microswitch	Standard ¹⁾				42				
	Standard  ¹⁾				33				
	Gold plated contacts ¹⁾				84				
Range	Range [bar]	Over pressure [bar]		Range [psi]	Over pressure [psi]				
	1 ... 10	200	78	14 ... 150	2900		G8		
	1 ... 16	200	79	14 ... 250	2900		G9		
	2 ... 25	200	80	30 ... 400	2900		H0		
	4 ... 40	200	81	60 ... 500	2900		H1		
	6 ... 60	200	82	85 ... 850	2900		H2		
	10 ... 100	200	83	150 ... 1500	2900		H3		
Sensor	Sensor material	Sensor housing material		Range					
	FKM Membrane	Aluminium EN AW-6082 AlMgSi1 anodized		78, 79			761		
	FKM Membrane	Aluminium EN AW-6082 AlMgSi1 anodized		80, 81			762		
	FKM Membrane	Aluminium EN AW-6082 AlMgSi1 anodized		82, 83			763		
Pressure connection	G1/8" female							02	
	G1/4" female							04	
	M10x1 female ²⁾							03	
Accessories	Flange with O-Ring ³⁾								11
	Female electrical connector EN 175301-803-A (DIN43650-A)								46
	Welsh plug G1/4"								74
	Fixing set								V3
	Covering cap								15
	Lead seal (manipulation protection)								16
	Switch point adjustment on customers request								
	Please indicate when ordering: - Switchpoint including measurement unit (kPa, bar, MPa, psi, abs. or rel.) - Increasing or decreasing								88
Damping elements and snubber see data sheet H72258									

¹⁾ Switching differential not adjustable

²⁾ Please ask us

³⁾ Only with pressure connection 04 (G1/4"), others upon request

Standard products (extra short lead time)

Product No.	Type Code	Pressure range [bar]	Over pressure max. [bar]	Switching differential [bar]
PST4M164	9M4 4279 761 04 0000 0000 15 46 V3	1 ... 16	200	0.2 ... 1.7 (fixed)
PST4M404	9M4 4281 762 04 0000 0000 15 46 V3	4 ... 40	200	1.2 ... 4.5 (fixed)
PST4M1004	9M4 4283 763 04 0000 0000 15 46 V3	10 ... 100	200	4 ... 16 (fixed)
PST4M16F4	9M4 4279 761 04 0000 0000 11 15 46 74 V3	1 ... 16	200	0.2 ... 1.7 (fixed)
PST4M40F4	9M4 4281 762 04 0000 0000 11 15 46 74 V3	4 ... 40	200	1.2 ... 4.5 (fixed)
PST4M100F4	9M4 4283 763 04 0000 0000 11 15 46 74 V3	10 ... 100	200	4 ... 16 (fixed)

Specifications		
Accuracy	Repeatability	± 2.0 % FS typ.
	Switching differential	See table
	Adjustment range switchpoint ²⁾	10 % ... 90 % FS
	Temperature dependence switching point	approx. + 0.1% FS/°C typ.
Environmental conditions	Ambient temperature	0°C ... +80°C
	Media temperature	0°C ... +80°C
	Storage temperature	-40°C ... +85°C
	Protection ¹⁾	IP65
	Humidity	Max. 95 % relative
	Vibration	Switch IEC/EN 60068-2-6: 10...59 Hz: ±0.75 mm Ampl. 59...500 Hz: 5 g
	Shock	50 g / 3 ms
Mechanical Data	Sensor	See ordering information
	Housing	Aluminium EN AW-6082 AlMgSi1 anodized
	Sealing	FKM
	Housing seal	EPDM 75 Sh
	Male electrical plug	Polyamide (PA)
	Mounting torque	G 1/4": MA= 32 ... 40 Nm
	Installation	any position
	Weight	~ 200 g
Microswitch	Rating	See table
	Resistance of insulation	500 VDC > 10 MΩ
	Dielectric strength	(IEC/EN 60730-1) >1.5 kV AC/60 s terminal ground >500 VAC/60 s via open contacts
Electrical connection	Electrical connections	EN175301-803-A (DIN43650-A)
	Female electrical connector	Cable-Ø: 4...9 mm Terminal screw: 4 x 0.5...1.5 mm ²

¹⁾ Provided female connector is mounted according to instructions

²⁾ Other adjustment ranges upon request

Dimensions

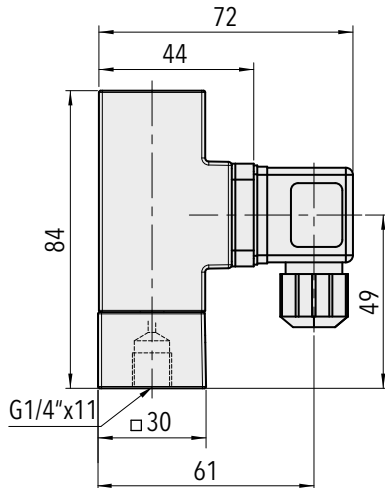

9M4.XXXX.7XX.04.46.V3

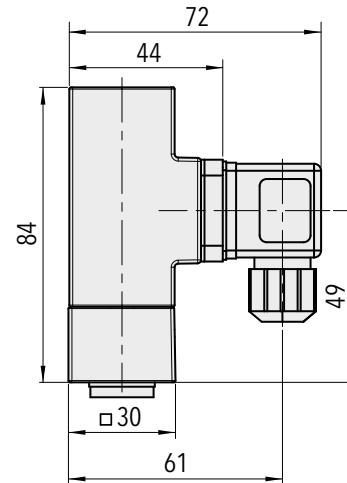
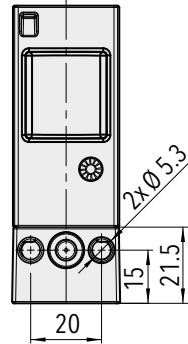

9M4.XXXX.7XX.04.11.46.74.V3

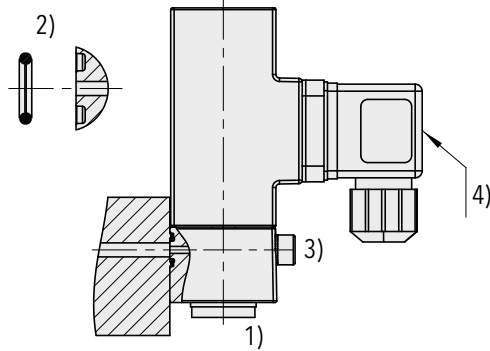
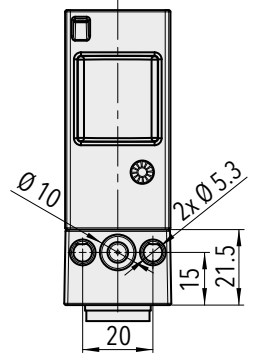

9M4.XXXX.XXX.XX.11

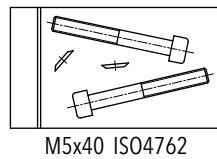

9M4.XXXX.XXX.XX.V3

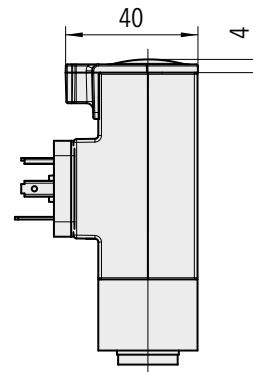

9M4.XXXX.XXX.XX.15

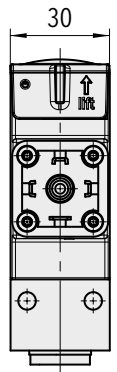

- 1) Torque: G 1/4": $M_A = 32 \dots 40 \text{ Nm}$
- 2) O-Ring: $\varnothing 6.75 \times 1.78$ NBR 90 Sh
- 3) Fixing screw: M5; property class: 8.8; torque: $4.5 \dots 6 \text{ Nm}$
- 4) Torque connector center screw: max. 0.4 Nm

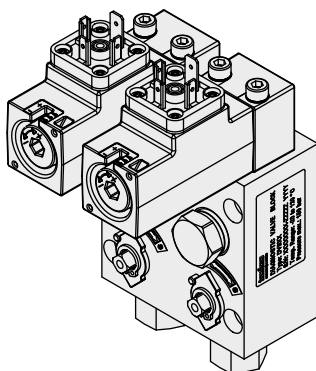

Diagnostic Valve Bloc (DVB)
see specification sheet H72361

Switching differential typ. @ 25°C

Measuring range	[bar]	1 ... 10	1 ... 16	2 ... 25	4 ... 40	6 ... 60	10 ... 100
membrane sensor	[psi]	14 ... 150	14 ... 250	30 ... 400	60 ... 500	85 ... 850	150 ... 1500
Microswitch 42/84/33:	[bar]	0.2 ... 1.7	0.2 ... 1.7	1.2 ... 4.5	1.2 ... 4.5	4 ... 16	4 ... 16
Switching differential not adjustable	[psi]	3 ... 24.5	3 ... 24.5	18 ... 66	18 ... 66	58 ... 232	58 ... 232

Electrical data switch

Type	Features	Rating	
		Resistive Load (Inductive Load)	
		AC	DC
42/33 (Standard)	Silver contacts	250 V, 6 (1) A	220 V, 0.25 (0.1) A 110 V, 0.5 (0.2) A 60 V, 1(0.5) A 24 V, 3 (2) A 12 V, 6 (6) A
84	Gold plated contacts, suitable for intrinsically safe control circuits	max. 30 V, 0.1 (0.1) A min. 5 V, 5 mA	

Electrical Connection

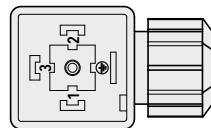
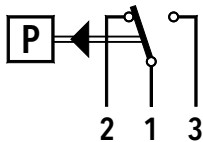

EN175301-803-A

Additional information

Documents

Data sheet	www.trafag.com/H72368
Instructions	www.trafag.com/H73367
Flyer	www.trafag.com/H70668

DIFFERENTIAL PRESSURE PICOSTAT

Swiss based Trafag is a leading international supplier of high quality sensors and monitoring instruments for measurement of pressure and temperature.



Applications

- Shipbuilding
- Engine manufacturing
- Machine tools
- Hydraulics

Features

- Compact design
- Rugged housing
- High repeatability
- Protection IP65 (with plug connector)
- Any mounting position possible

Technical Data			
Measuring principle	Bellow	Repeatability	± 1.0 % FS typ.
Measuring range	-1 ... 6 and -1 ... 8 bar	Media temperature	-25°C ... +120°C
Differential pressure	0 ... 4 and 0 ... 6 bar	Ambient temperature	-25°C ... +85°C
Output signal	1 Floating change-over contact (SPDT)	Approval / conformity	DNV-GL EN60730-1/ EN60730-2-6: Typ 2.B.H
Switching differential	Not adjustable		

Subject to change

Ordering information/type code

					9D0	XX	XX	XXX	XX	XX
Microswitch	Big switching differential ¹⁾					20				
	Small switching differential ¹⁾					28				
	Switch with gold plated contacts ¹⁾					83				
Range	Range [bar]	Differential pressure [bar]	Over pressure [bar]	Burst pressure [bar]						
	-1 ... 6	0 ... 4	8	11.5		76				
	-1 ... 8	0 ... 6	12	26		77				
Sensor	Sensor material	Sensor housing material		Range						
	Bronze (CuZn6)	Brass (CuZn39Pb3)		76		770				
	Bronze (CuZn6)	Brass (CuZn39Pb3)		77		771				
Pressure connection	G1/4" female									04
Accessories	Flange with O-Ring									11
	Covering									15
	Lead seal (manipulation protection)									16
	Female electrical connector DIN43650-A									58
	Welsh plug G1/8"									57
	Welsh plug G1/4"									74
	Fixing set									V3
	Damping elements and snubber see data sheet H72258									

¹⁾ Switching differential not adjustable

Standard products (extra short lead time)

Product No.	Type Code	Pressure range [bar]	Differential pressure [bar]	Over pressure max. [bar]	Switching differential [bar]
PSTD4	9D0 2076 770 04 0000 0000 15 58 V3	-1 ... 6	0 ... 4	8	0.2 (fixed)
PSTD6	9D0 2077 771 04 0000 0000 15 58 V3	-1 ... 8	0 ... 6	12	0.3 (fixed)

Specifications		
Accuracy	Repeatability	± 1.0 % FS typ.
	Switching differential	See table
	Adjustment range switchpoint ¹⁾	10% ... 90% FS
Environmental conditions	Ambient temperature	-25°C ... +85°C
	Media temperature	-25°C ... +120°C
	Storage temperature	-40°C ... +85°C
	Protection	IP65
	Humidity	Max. 95 % relative
	Vibration	5...25 Hz: ±1.6 mm 25...100 Hz: 4g
	Shock	50g/ 11ms
Mechanical Data	Sensor	Bronze (CuSn8)
	Housing	Brass CuZn39Pb3
	Sealing	-
	Male electrical plug	Polyamide PA
	Mounting torque	Max. 25 Nm
	Installation	any position
	Weight	~ 800 g
Microswitch	Rating	See table
	Resistance of insulation	> 2 MΩ
	Dielectric strength	1.45 kV terminal ground
	Life time (mechanical)	Microswitch 20: 1 Mio. cycles Microswitch 28/83: 10 Mio. cycles
Electrical connection	Electrical connections	EN175301-803-A (DIN43650-A)
	Female electrical connector	Cable-Ø: 6...13 mm Terminal screw: 4 x 0.5...1.5 mm ²

¹⁾ Other adjustment ranges upon request

Dimensions

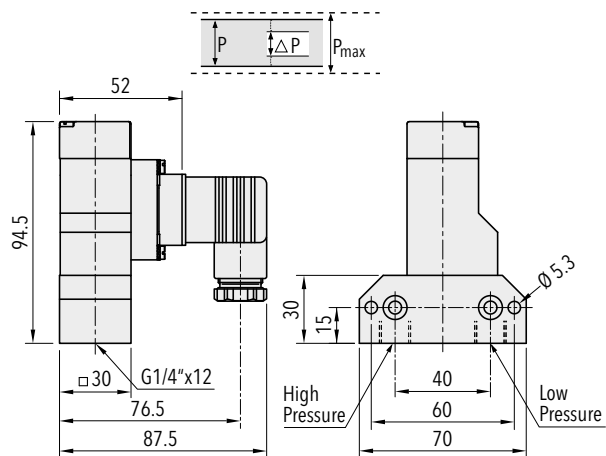

9D0.XX7X.77X.04.58.V3

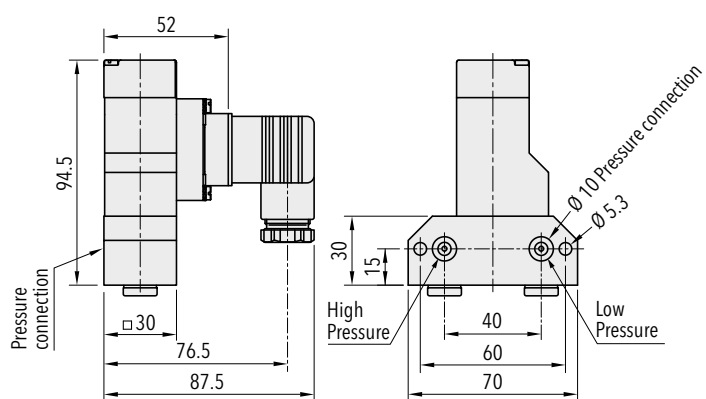

9D0.XX7X.77X.04.11.58.74.V3

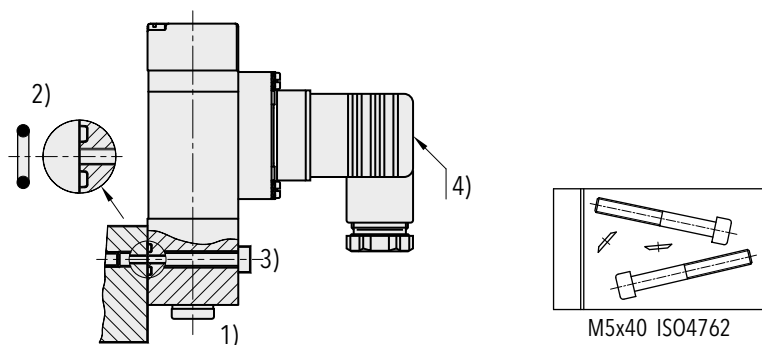

9D0.XXXX.XXX.XX.11

9D0.XXXX.XXX.XX.V3

- 1) Torque: G 1/8": $M_A = 16 \dots 20 \text{ Nm}$
G 1/4": $M_A = 32 \dots 40 \text{ Nm}$
- 2) O-Ring: $\varnothing 6.75 \times 1.78 \text{ NBR 70 Sh}$
- 3) Fixing screw: M5; property class: 8.8; torque: $4.5 \dots 6 \text{ Nm}$
- 4) Torque connector center screw: max. 0.4 Nm

Switching differential typ. @ 25°C

Measuring range of bellows sensor	[bar]	-1 ... 6	-1 ... 8
Microswitch 20 Switching differential (not adjustable)	[bar]	0.2	0.3
Microswitch 28/83 Switching differential (not adjustable)	[bar]	0.15	0.2

Electrical data switch

Type	Features	Rating	
		Resistive Load (Inductive Load)	
		AC	DC
20	Big switching differential	250 V, 10 (3) A	250 V, 0.1 (0.05) A 220 V, 0.25 (0.2) A 110 V, 0.5 (0.3) A 24 V, 2 (1) A
28	Small switching differential	250 V, 3 (1) A	250 V, 0.1 (0.05) A 220 V, 0.25 (0.2) A 110 V, 0.5 (0.3) A 24 V, 2 (1) A
83	Gold plated contacts, suitable for intrinsically safe control circuits	max. 30 V, 0.3 (0.2) A min. 5 V, 1 mA	

Electrical Connection

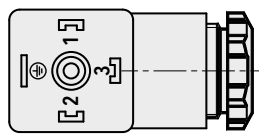
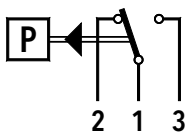

DIN 43650-5

Additional information

Documents	Data sheet	www.trafag.com/H72273
	Instructions	www.trafag.com/H73273
	Flyer	www.trafag.com/H70913

PICOSTAT

Swiss based Trafag is a leading international supplier of high quality sensors and monitoring instruments for measurement of pressure and temperature.



Applications

- Shipbuilding
- Engine manufacturing
- Railways
- Machine tools



Features

- Compact design
- Rugged housing
- Improved vibration resistance
- Protection IP65
- Any mounting position possible

Technical Data			
Measuring principle	Bellow	Repeatability	± 0.5 % FS typ. @ 25°C
Measuring range	0 ... 4 to 2 ... 25 bar	Media temperature	-25°C ... +125°C
Output signal	1 Floating change-over contact (SPDT)	Ambient temperature	-25°C ... +85°C
Switching differential	Not adjustable	Approval / conformity	BV, CCS, DNV-GL, LRS, NKK EN60730-1/ EN60730-2-6: Typ 2.B.H

Subject to change

Ordering information/type code

		9B4 .	XX	XX	XXX	XX	XX
Micro-switch	Standard ¹⁾		33				
Range	Range [bar]						
	0 ... 4					76	
	0 ... 6					77	
	1 ... 10					78	
	1 ... 16					79	
	2 ... 25					80	
	4 ... 40 ²⁾					81	
Sensor	Sensor material	Sensor housing material	Range				
	Bronze (CuSn6)	Aluminium EN AW-6026 AlMgSiPb0.4 anodized	76, 77			750	
	Bronze (CuSn6)	Aluminium EN AW-6026 AlMgSiPb0.4 anodized	78, 79			751	
	Bronze (CuSn6)	Aluminium EN AW-6026 AlMgSiPb0.4 anodized	80, 81			752	
Pressure connection	G1/4" female						04
Accessories	Flange with O-Ring						11
	Female electrical connector EN175301-803-A (DIN43650-A)						46
	Welsh plug G1/4"						74
	Fixing set						V3
	Switch point adjustment on customers request						
	Please indicate when ordering:						88
	- Switchpoint including measurement unit (kPa, bar, MPa, psi, abs. or rel.)						
	- Increasing or decreasing						
	Damping elements and snubber see data sheet H72258						

¹⁾ Switching differential not adjustable

²⁾ Without ship approval

Specifications		
Accuracy	Repeatability	± 0.5 % FS typ. @ 25°C
	Switching differential	See table
	Adjustment range switchpoint ²⁾	10% ... 90% FS
	Temperature dependence switching point	Appr. 0.1% FS/°C typ.
Environmental conditions	Ambient temperature	-25°C ... +85°C
	Media temperature	-25°C ... +125°C
	Storage temperature	-40°C ... +85°C
	Protection ¹⁾	IP65
	Humidity	Max. 95 % relative
	Vibration	Switch 33: IEC/EN 60068-2-6 10..59 Hz: ±0.75mm Ampl. 59..500 Hz: 10 g
	Shock	50g/ 3 ms
Mechanical Data	Sensor	See ordering information
	Housing	Aluminium EN AW-6026 AlMgSiPb0.4 anodized
	Sealing	FKM 75 Sh
	Male electrical plug	PA, Polyamide
	Mounting torque	See accessories
	Installation	any position
	Weight	~ 160 g
Microswitch	Rating	See table
	Resistance of insulation	500 VDC > 10 MΩ
	Dielectric strength	IEC/EN 60730-1: >1.45 kVAC/60 s terminal ground >500 VAC/60 s against open contacts
Electrical connection	Electrical connections	EN175301-803-A (DIN43650-A)
	Female electrical connector	Cable-Ø: 4...9 mm Terminal screw: 4 x 0.5...1.5 mm ²

¹⁾ Provided female connector is mounted according to instructions

²⁾ Other adjustment ranges upon request

Dimensions

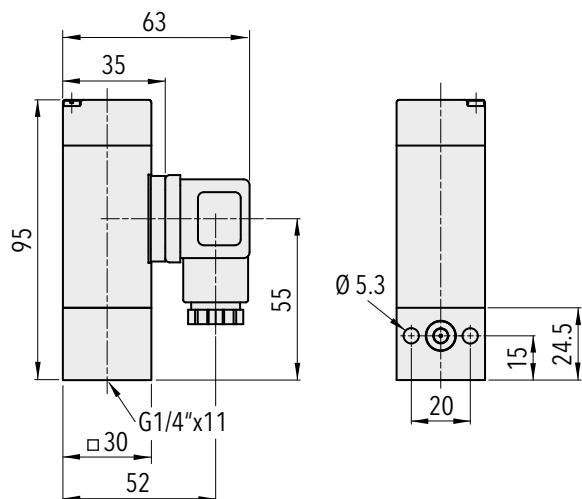

9B4.XXXX.7XX.04.46.V3

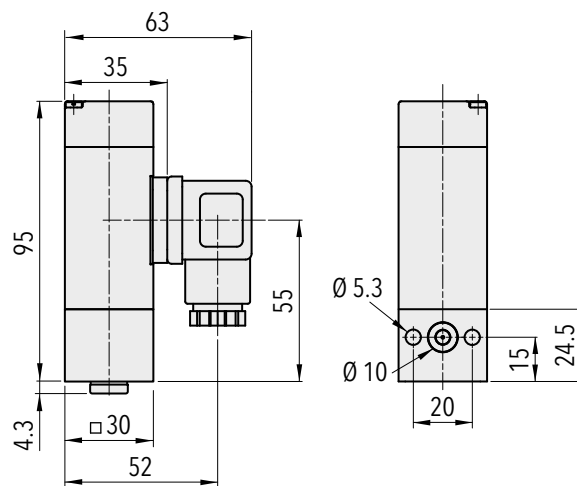

9B4.XXXX.7XX.04.11.46.74.V3

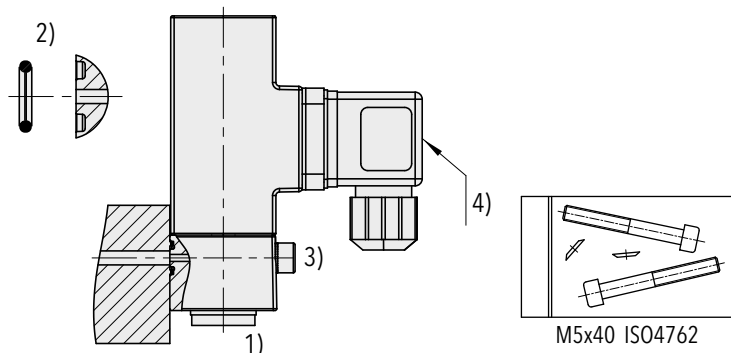

9B4.XXXX.XXX.XX.11

9B4.XXXX.XXX.XX.V3

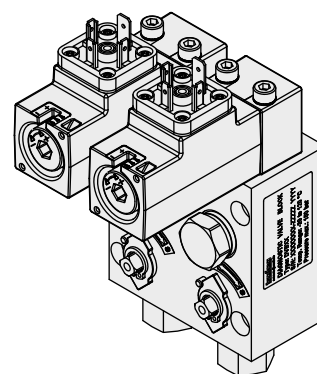

Diagnostic Valve Bloc (DVB)
see specification sheet H72361

- 1) Torque: G 1/4": $M_A = 32 \dots 40 \text{ Nm}$
- 2) O-Ring: $\varnothing 6.75 \times 1.78$
 - $\geq 250 \text{ bar FKM 90 Sh}$
 - $< 250 \text{ bar FKM 70 Sh}$
- 3) Fixing screw: M5; property class: 8.8; torque: 4.5...6 Nm
- 4) Torque connector center screw: max. 0.4 Nm

Switching differential typ. @ 25°C

Measuring range bellows sensor	[bar]	0 ... 4	0 ... 6	1 ... 10	1 ... 16	2 ... 25	4 ... 40
Microswitch 33:	[bar]	0.3	0.3	0.6	0.6	1.5	1.8
Switching differential not adjustable							

Electrical data switch

Type	Features	Rating	
		Resistive Load (Inductive Load)	
		AC	DC
33	Silver contacts	240 V, 6 (2) A	220 V, 0.2 (0.1) A 110 V, 0.4 (0.25) A 48 V, 2 (1) A 24 V, 6 (3) A 12 V, 6 (6) A

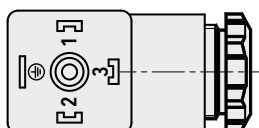
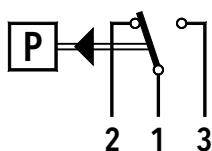

EN175301-803-A

Additional information

Documents	Data sheet	www.trafag.com/H72362
	Instructions	www.trafag.com/H73362
	Flyer	www.trafag.com/H70923

PRESSOSTAT

Swiss based Trafag is a leading international supplier of high quality sensors and monitoring instruments for measurement of pressure and temperature.



Applications

- Shipbuilding
- Engine manufacturing
- Railways
- Machine tools
- Hydraulics

Features

- Rugged aluminium housing
- Protection IP65
- Any mounting position possible

Technical Data			
Measuring principle	Bellow	Repeatability	± 1.0 % FS typ.
Measuring range	-0.9 ... 1.5 to 10 ... 100 bar 5 ... 50 to 125 ... 1500 psi	Media temperature	-40°C ... +150°C
Output signal	1 Floating change-over contact (SPDT)	Ambient temperature	-25°C ... +70°C
Switching differential	Not adjustable	Approval / conformity	ABS, BV, CCS, DNV, GL, KRS, LRS, RINA EN60730-1/ EN60730-2-6: Typ 2.B.H



Subject to change

Ordering information/type code

		XXX	XX	XX	XXXXXX	XX	XX
Custom build code	With display and adjusting screw	900					
	Without display, with adjusting screw	904					
	With display and adjusting knob	912					
Microswitch	Small switching differential, standard vibration resistance ^{1) 2)}					10	
	Average switching differential, standard vibration resistance ¹⁾					11	
	Average switching differential, increased vibration resistance ¹⁾					23	
	Large switching differential, high vibration resistance ¹⁾					26	
	With gold plated contacts, standard vibration resistance ¹⁾					21	

Range	Range [bar]	Over pressure [bar]	Burst pressure [bar]	Range [psi]	Over pressure [psi]	Burst pressure [psi]	
	-0.9 ... 1.5	10	13	72	5 ... 50	175	350
0.2 ... 1.6	10	13	73	10 ... 100	350	500	G8
0.2 ... 2.5	10	13	75	25 ... 200	350	500	G9
0 ... 4	12	26	76	50 ... 500	500	1000	H1
0 ... 6	12	26	77	125 ... 1500	1500	2300	H3
1 ... 10	24	36	78				
1 ... 16	24	36	79				
2 ... 25	40	75	80				
4 ... 40	40	75	81				
6 ... 60	100	160	82				
10 ... 100	100	160	83				

Sensor	Sensor material	Sensor housing material	Thread	Range		Sensor material	Sensor housing material	Thread	Range	
	Bronze bellow (CuSn6)	Brass (CuZn39Pb3)	G1/4" female	72	900	Bronze bellow (CuSn6)	Brass chemically nickel plated	G1/4" female	78, 79	955
Bronze bellow (CuSn6)	Brass (CuZn39Pb3)	G1/4" female	73, 75	901	Bronze bellow (CuSn6)	Brass chemically nickel plated	G1/4" female	80, 81	957	
Bronze bellow (CuSn6)	Brass (CuZn39Pb3)	G1/4" female	76, 77	903	Bronze bellow (CuSn6)	Brass chemically nickel plated	G1/2" male	72	959	
Bronze bellow (CuSn6)	Brass (CuZn39Pb3)	G1/4" female	78, 79	905	Bronze bellow (CuSn6)	Brass chemically nickel plated	G1/2" male	73, 75	952	
Bronze bellow (CuSn6)	Brass (CuZn39Pb3)	G1/4" female	80, 81	907	Bronze bellow (CuSn6)	Brass chemically nickel plated	G1/2" male	76, 77	954	
Stainless steel 1.4435	Brass (CuZn39Pb3)	G1/4" female	82, 83	940	Bronze bellow (CuSn6)	Brass chemically nickel plated	G1/2" male	78, 79	956	
Bronze bellow (CuSn6)	Brass (CuZn39Pb3)	G1/2" male	72	909	Bronze bellow (CuSn6)	Brass chemically nickel plated	G1/2" male	80, 81	958	
Bronze bellow (CuSn6)	Brass (CuZn39Pb3)	G1/2" male	73, 75	902	Stainless steel 1.4435	Brass nickel plated	G1/4" female	72	800	
Bronze bellow (CuSn6)	Brass (CuZn39Pb3)	G1/2" male	76, 77	904	Stainless steel 1.4435	Brass nickel plated	G1/4" female	73, 75	801	
Bronze bellow (CuSn6)	Brass (CuZn39Pb3)	G1/2" male	78, 79	906	Stainless steel 1.4435	Brass nickel plated	G1/4" female	76, 77	803	
Bronze bellow (CuSn6)	Brass (CuZn39Pb3)	G1/2" male	80, 81	908	Stainless steel 1.4435	Brass nickel plated	G1/4" female	78, 79	805	
Stainless steel 1.4435	Brass	G1/2" male	82, 83	941	Stainless steel 1.4435	Brass nickel plated	G1/4" female	80, 81	807	
Bronze bellows (CuSn6)	Brass (CuZn39Pb3)	1/4" NPT female	G6	G6.103	Stainless steel 1.4435	Brass nickel plated	G1/4" female	82, 83	840	
Bronze bellows (CuSn6)	Brass (CuZn39Pb3)	1/4" NPT female	G8	G8.105	Stainless steel 1.4435	Brass nickel plated	G1/2" male	72	809	
Bronze bellows (CuSn6)	Brass (CuZn39Pb3)	1/4" NPT female	G9	G9.105	Stainless steel 1.4435	Brass nickel plated	G1/2" male	73, 75	802	
Bronze bellows (CuSn6)	Brass (CuZn39Pb3)	1/4" NPT female	H1	H1.107	Stainless steel 1.4435	Brass nickel plated	G1/2" male	76, 77	804	
Bronze bellows (CuSn6)	Brass (CuZn39Pb3)	1/4" NPT female	H3	H3.140	Stainless steel 1.4435	Brass nickel plated	G1/2" male	78, 79	806	
Bronze bellow (CuSn6)	Brass chemically nickel plated	G1/4" female	72	950	Stainless steel 1.4435	Brass nickel plated	G1/2" male	80, 81	808	
Bronze bellow (CuSn6)	Brass chemically nickel plated	G1/4" female	73, 75	951	Stainless steel 1.4435	Brass nickel plated	G1/2" male	82, 83	841	
Bronze bellow (CuSn6)	Brass chemically nickel plated	G1/4" female	76, 77	953						

	XXX	XX	XX	XXXXXX	XX	XX
Fixing	Direct on sensor or housing					00
	With mounting bracket					31
Accessories	Lead seal (manipulation protection)					16
	Screwed cable gland M20x1.5 (EN50262) 					07
	Screwed cable gland M24x1.5 (DIN89280) 					27
	Screwed cable gland M18x1.5 (DIN89280) 					40
	Without screwed cable gland					33
	Railway version (IEC 61373, category 2)					28
	Damping elements and snubber see data sheet H72258					

- ¹⁾ Switching differential not adjustable
²⁾ Not suitable for applications under vibration

Standard products (extra short lead time)						
Product No.	Type Code	Pressure range [bar]	Over pressure max. [bar]	Switching differential [bar]	Diameter Y [mm]	Length X [mm]
P1.5	900 2672 900	-0.9 ... 1.5	10	0.1 (fixed)	45	56.5
P2.5	900 2675 901	0.2 ... 2.5	10	0.1 (fixed)	45	56.5
P4	900 2376 903	0 ... 4	12	0.2 (fixed)	33	47
P6	900 2377 903	0 ... 6	12	0.2 (fixed)	33	47
P10	900 2378 905	1 ... 10	24	0.4 (fixed)	27	42.5
P16	900 2379 905	1 ... 16	24	0.4 (fixed)	27	42.5
P25	900 2380 907	2 ... 25	40	1 (fixed)	33	47
P40	900 2381 907	4 ... 40	40	1 (fixed)	33	47
PS1.5	904 2672 900	-0.9 ... 1.5	10	0.1 (fixed)	45	56.5
PS2.5	904 2675 901	0.2 ... 2.5	10	0.1 (fixed)	45	56.5
PS6	904 2377 903	0 ... 6	12	0.2 (fixed)	33	47
PS16	904 2379 905	1 ... 16	24	0.4 (fixed)	27	42.5
PS40	904 2381 907	4 ... 40	40	1 (fixed)	27	42.5

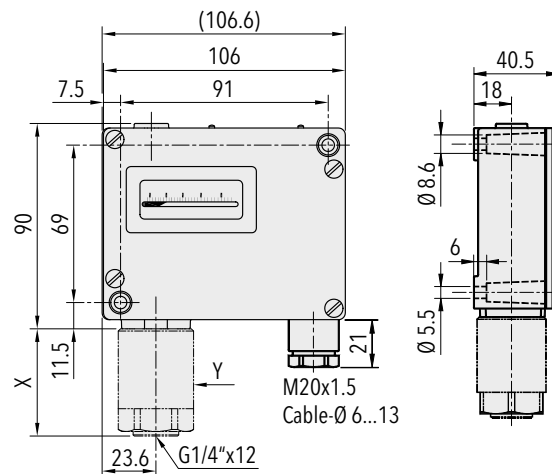

Specifications		
Accuracy	Repeatability	± 1.0 % FS typ.
	Scale accuracy typ.	± 2.0 % FS typ.
	Switching differential	See table
	Adjustment range switchpoint ¹⁾	10% ... 90% FS
Environmental conditions	Ambient temperature	-25°C ... +70°C
	Media temperature	-40°C ... +150°C
	Storage temperature	-25°C ... +85°C
	Protection	IP65
	Humidity	Max. 95% relative
	Vibration	Switch 23/26, 5...25 Hz: ±1.6 mm 25...100 Hz: 4g Ranges 72, 73, 75, 5...50 Hz: 20 mm/sec.
	Shock	50 g / 11ms
Mechanical Data	Sensor	See ordering information
	Housing	AlSi10Mg/ Epoxy coated
	Sealing	NBR
	Housing seal	EPDM 75 Sh
	Screwed cable gland	Brass nickel plated
	Male electrical plug	PA, Polyamide
	Mounting torque	max. 25 Nm
	Installation	any position
	Weight	~ 710 g
Microswitch	Rating	See table
	Resistance of insulation	> 2 MΩ
	Dielectric strength	U ≤ 250V: 1.45 kV / U ≤ 500V: 2 kV terminal ground
	Life time (mechanical)	Microswitch 10/11: 20 Mio. cycles Microswitch 21: 0.5 Mio. cycles Microswitch 23/26: 0.3 Mio. cycles
Electrical connection	Electrical connections	Terminal screw
	Cable gland	M20x1.5 Cable-Ø 6...13 mm
	Terminal screw	3 x 1.5...4 mm ²

¹⁾ Other adjustment ranges upon request

Additional information		
Documents	Data sheet	www.trafag.com/H72252
	Instructions	www.trafag.com/H71261
	Flyer	www.trafag.com/H70911

Dimensions

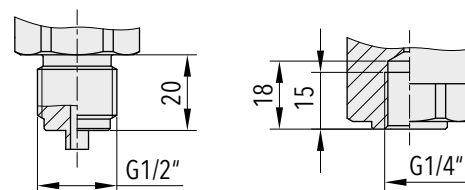
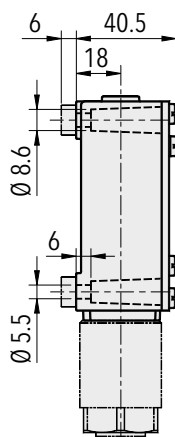
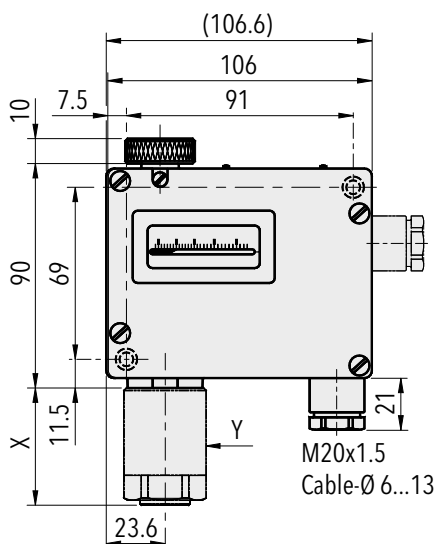

G1/2" male

G1/4" female

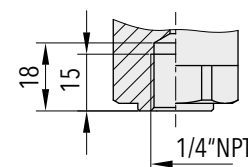

1/4" NPT female

Dimension X and Y see data sheet H72271

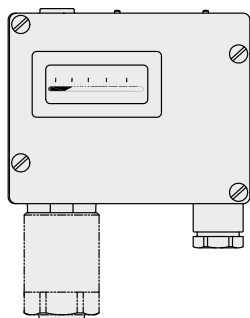

900.XX.XX.XXX.XX.XX

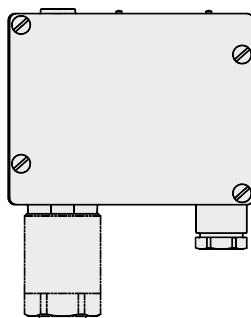

904.XX.XX.XXX.XX.XX

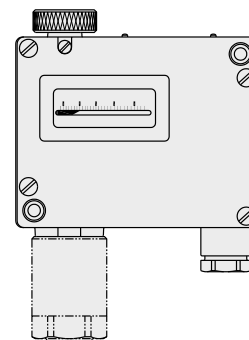

912.XX.XX.XXX.XX.XX

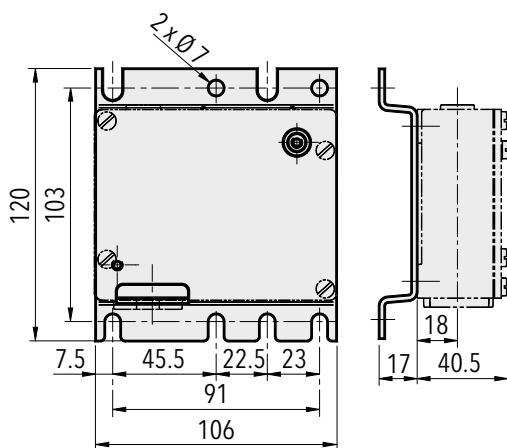

9XX.XX.XX.XXX.31.XX

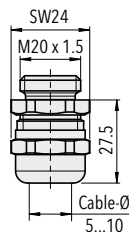

9XX.XX.XX.XXX.XX.07

M20x1.5

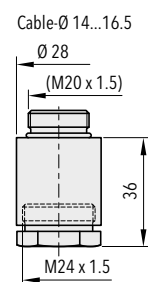

9XX.XX.XX.XXX.XX.27

M24x1.5

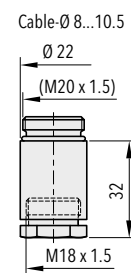

9XX.XX.XX.XXX.XX.40

M18x1.5





Switching differential typ. @ 25°C

Measuring range of bellows sensor	[bar]	-0.9 ... 1.5	0 ... 4	1 ... 10	2 ... 25	6 ... 60
		0.2 ... 1.6	0 ... 6	1 ... 16	4 ... 40	10 ... 100
Microswitch 10 Switching differential (not adjustable)	[bar]	0.03	0.08	0.2	0.5	1.5
Microswitch 11/21/23 Switching differential (not adjustable)	[bar]	0.1	0.2	0.4	1.0	3.0
Microswitch 26 Switching differential (not adjustable)	[bar]	0.1	0.3	0.8	2.0	5.0

Measuring range of bellows sensor	[psi]	5 ... 50	10 ... 100	50 ... 500	125 ... 1500
			25 ... 200		
Microswitch 10 Switching differential (not adjustable)	[psi]	1.2	3	7.5	22
Microswitch 11/21/23 Switching differential (not adjustable)	[psi]	3	6	14.5	44
Microswitch 26 Switching differential (not adjustable)	[psi]	4.4	12	30	72.5

Electrical data switch

Type	Features	Rating	
		Resistive Load (Inductive Load)	
		AC	DC
10	Small switching differential (not recommended for applications under vibrations)	125 V 10 (1.5) A 250 V 10 (1.25) A	250 V 0.2 (0.02) A 125 V 0.4 (0.03) A 30 V 2 (1) A 14 V 15 (2.5) A
11	Average switching differential, standard vibration resistance	125 V 15 (1.5) A 250 V 15 (1.25) A 500 V 10 (0.75) A	250 V 0.25 (0.03) A 125 V 0.5 (0.05) A 30 V 6 (1.5) A 14 V 15 (1.5) A
23 	Average switching differential, increased vibration resistance	125 V 15 (1.5) A 250 V 15 (1.25) A 500 V 10 (0.75) A	250 V 0.3 (0.05) A 125 V 0.6 (0.1) A 30 V 15 (1.5) A 14 V 15 (1.5) A
26 	Large switching differential, high vibration resistance	125 V 15 (1.5) A 250 V 15 (1.25) A 500 V 10 (0.75) A	250 V 0.3 (0.2) A 125 V 0.75 (0.4) A 30 V 15 (1.5) A 14 V 15 (1.5) A
21	With gold plated contacts, standard vibration resistance	24 V 0.1 (0.1) A 12 V 1.0 (1.0) A 5 V 2.0 (2.0) A	24 V 0.1 (0.1) A 12 V 1.0 (1.0) A 5 V 2.0 (2.0) A

Electrical connection

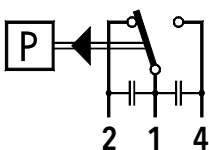

Switch 10/11/23

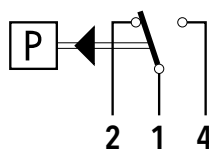

Switch 21/26

VARI PRESSOSTAT

Swiss based Trafag is a leading international supplier of high quality sensors and monitoring instruments for measurement of pressure and temperature.



Applications

- Shipbuilding
- Engine manufacturing
- Railways
- Machine tools
- Hydraulics

Features

- Rugged aluminium housing
- Protection IP65
- Any mounting position possible

Technical Data			
Measuring principle	Bellow	Repeatability	± 1.0 % FS typ.
Measuring range	-0.9 ... 1.5 to 4 ... 40 bar 5 ... 50 to 50 ... 500 psi	Media temperature	-40°C ... +150°C
Output signal	1 Floating change-over contact (SPDT)	Ambient temperature	-25°C ... +70°C
Switching differential	Adjustable	Approval / conformity	ABS, BV, CCS, DNV, GL, KRS, LRS, RINA EN60730-1/ EN60730-2-6: Typ 2.B.H
Switching point	Calibration for decreasing pressure		

Subject to change



Ordering information/type code

		XXX	XX	XX	XXXXXX	XX	XX
Custom build code	Large adjustable switching differential, with display and internal adjustment screw	903					
	Large adjustable switching differential, without display, with internal adjustment screw	907					
	Large adjustable switching differential, with display and external adjustment screw	915					
	Small adjustable switching differential, with display and internal adjustment screw	940					
	Small adjustable switching differential, without display, with internal adjustment screw	941					
	Small adjustable switching differential, with display and external adjustment screw	942					
Microswitch	Standard vibration resistance ^{1) 3)}					11	
	High vibration resistance ³⁾					12	
	Increased vibration resistance  ³⁾					23	

Range	Range	Over pressure	Burst pressure	Range	Over pressure	Burst pressure		
	[bar]	[bar]	[bar]	[psi]	[psi]	[psi]		
	-0.9 ... 1.5	10	13	72	5 ... 50	175	350	G6
	0.2 ... 1.6	10	13	73	10 ... 100	350	500	G8
	0.2 ... 2.5	10	13	75	25 ... 200	350	500	G9
	0 ... 4	12	26	76	50 ... 500	500	1000	H1
	0 ... 6	12	26	77				
	1 ... 10	24	36	78				
	1 ... 16	24	36	79				
	2 ... 25	40	75	80				
	4 ... 40	40	75	81				

Sensor	Sensor material	Sensor housing material	Thread	Range		Sensor material	Sensor housing material	Thread	Range	
		Bronze bellow (CuSn6)	Brass (CuZn39Pb3)	G1/4" female	72	900	Bronze bellow (CuSn6)	Brass chemically nickel plated	G1/4" female	78, 79
	Bronze bellow (CuSn6)	Brass (CuZn39Pb3)	G1/4" female	73, 75	901	Bronze bellow (CuSn6)	Brass chemically nickel plated	G1/4" female	80, 81	957
	Bronze bellow (CuSn6)	Brass (CuZn39Pb3)	G1/4" female	76, 77	903	Bronze bellow (CuSn6)	Brass chemically nickel plated	G1/2" male	72	959
	Bronze bellow (CuSn6)	Brass (CuZn39Pb3)	G1/4" female	78, 79	905	Bronze bellow (CuSn6)	Brass chemically nickel plated	G1/2" male	73, 75	952
	Bronze bellow (CuSn6)	Brass (CuZn39Pb3)	G1/4" female	80, 81	907	Bronze bellow (CuSn6)	Brass chemically nickel plated	G1/2" male	76, 77	954
	Bellow stainless steel 1.4435	Brass (CuZn39Pb3)	G1/4" female	82, 83	940	Bronze bellow (CuSn6)	Brass chemically nickel plated	G1/2" male	78, 79	956
	Bronze bellow (CuSn6)	Brass (CuZn39Pb3)	G1/2" male	72	909	Bronze bellow (CuSn6)	Brass chemically nickel plated	G1/2" male	80, 81	958
	Bronze bellow (CuSn6)	Brass (CuZn39Pb3)	G1/2" male	73, 75	902	Bellows stainless steel 1.4435 ²⁾	Brass nickel plated	G1/4" female	72	800
	Bronze bellow (CuSn6)	Brass (CuZn39Pb3)	G1/2" male	76, 77	904	Bellows stainless steel 1.4435 ²⁾	Brass nickel plated	G1/4" female	73, 75	801
	Bronze bellow (CuSn6)	Brass (CuZn39Pb3)	G1/2" male	78, 79	906	Bellows stainless steel 1.4435 ²⁾	Brass nickel plated	G1/4" female	76, 77	803
	Bronze bellow (CuSn6)	Brass (CuZn39Pb3)	G1/2" male	80, 81	908	Bellows stainless steel 1.4435 ²⁾	Brass nickel plated	G1/4" female	78, 79	805
	Bellow stainless steel 1.4435	Brass (CuZn39Pb3)	G1/2" male	82, 83	941	Bellows stainless steel 1.4435 ²⁾	Brass nickel plated	G1/4" female	80, 81	807
	Bronze bellow (CuSn6)	Brass (CuZn39Pb3)	1/4" NPT female	G6	G6.103	Bellows stainless steel 1.4435 ²⁾	Brass nickel plated	G1/4" female	82, 83	840
	Bronze bellow (CuSn6)	Brass (CuZn39Pb3)	1/4" NPT female	G8	G8.105	Bellows stainless steel 1.4435 ²⁾	Brass nickel plated	G1/2" male	72	809
	Bronze bellow (CuSn6)	Brass (CuZn39Pb3)	1/4" NPT female	G9	G9.105	Bellows stainless steel 1.4435 ²⁾	Brass nickel plated	G1/2" male	73, 75	802
	Bronze bellow (CuSn6)	Brass (CuZn39Pb3)	1/4" NPT female	H1	H1.107	Bellows stainless steel 1.4435 ²⁾	Brass nickel plated	G1/2" male	76, 77	804
	Bronze bellow (CuSn6)	Brass chemically nickel plated	G1/4" female	72	950	Bellows stainless steel 1.4435 ²⁾	Brass nickel plated	G1/2" male	78, 79	806
	Bronze bellow (CuSn6)	Brass chemically nickel plated	G1/4" female	73, 75	951	Bellows stainless steel 1.4435 ²⁾	Brass nickel plated	G1/2" male	80, 81	808
	Bronze bellow (CuSn6)	Brass chemically nickel plated	G1/4" female	76, 77	953	Bellows stainless steel 1.4435 ²⁾	Brass nickel plated	G1/2" male	82, 83	841

PV/PVF 903/907/915/940/941/942

		XXX	XX	XX	XXXXXX	XX	XX
Fixing	Direct on sensor or housing						00
	With mounting bracket						31
Accessories	Lead seal (manipulation protection)						16
	Screwed cable gland M20x1.5 (EN50262) 						07
	Screwed cable gland M24x1.5 (DIN89280) 						27
	Screwed cable gland M18x1.5 (DIN89280) 						40
	Damping elements and snubber see data sheet H72258						

¹⁾ Switch 11 only with typ No. 940, 941, 942

²⁾ Material with medium contact: 1.4435

³⁾ Switching differential adjustable

Standard products (extra short lead time)

Product No.	Type Code	Pressure range [bar]	Over pressure max. [bar]	Switching differential [bar]	Diameter Y [mm]	Length X [mm]
PV6	903 2377 903	0 ... 6	12	0.4 ... 3.2 (adjustable)	33	47
PV16	903 2379 905	1 ... 16	24	1 ... 7.5 (adjustable)	27	42.5
PV40	903 2381 907	4 ... 40	40	3 ... 18 (adjustable)	27	42.5
PVF1.5	940 2372 900	-0.9 ... 1.5	10	0.06 ... 0.2 (adjustable)	45	56.5
PVF2.5	940 2375 901	0.2 ... 2.5	10	0.06 ... 0.2 (adjustable)	45	56.5
PVF6	940 2377 903	0 ... 6	12	0.2 ... 0.6 (adjustable)	33	47
PVF16	940 2379 905	1 ... 16	24	0.5 ... 1.6 (adjustable)	27	42.5

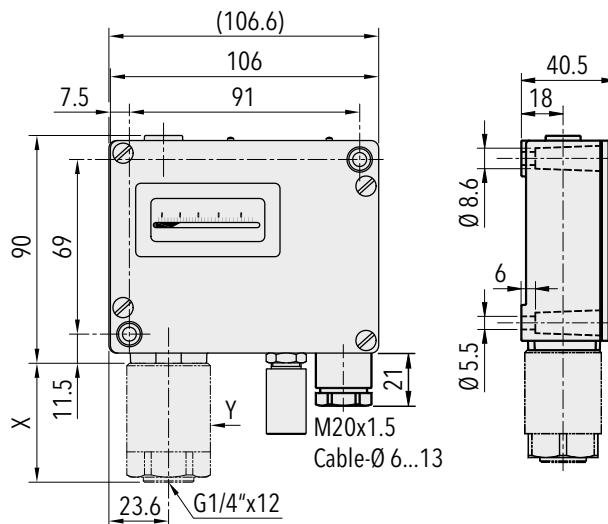

Specifications		
Accuracy	Repeatability	± 1.0 % FS typ.
	Scale accuracy typ.	± 2.0 % FS typ.
	Switching differential	See table
	Adjustment range switchpoint ¹⁾	10% ... 90% FS
Environmental conditions	Ambient temperature	-25°C ... +70°C
	Media temperature	-40°C ... +150°C
	Storage temperature	-25°C ... +85°C
	Protection	IP65
	Humidity	Max.95 % relative
	Vibration	5...25 Hz: ±1.6 mm 25...100 Hz: 4g Ranges 72, 73, 75 5...50 Hz: 20 mm/sec.
	Shock	50g/ 11ms
Mechanical Data	Sensor	See ordering information
	Housing	AlSi10Mg/ Epoxy coated
	Sealing	NBR
	Screwed cable gland	Brass nickel plated
	Mounting torque	Max. 25 Nm
	Installation	any position
	Weight	~ 710 g
Microswitch	Rating	See table
	Resistance of insulation	500 VDC/100 MΩ
	Dielectric strength	2 kV terminal ground
	Life time (mechanical)	Microswitch 11: 20 Mio. cycles Microswitch 12/23: 0.3 Mio. cycles
Electrical connection	Electrical connections	Terminal screw
	Cable gland	M20x1.5 Cable-Ø 6...13 mm
	Terminal screw	3 x 1.5...4 mm ²

¹⁾ Other adjustment ranges upon request

Additional information		
Documents	Data sheet	www.trafag.com/H72257
	Instructions	www.trafag.com/H71261
	Flyer	www.trafag.com/H70910

Dimensions

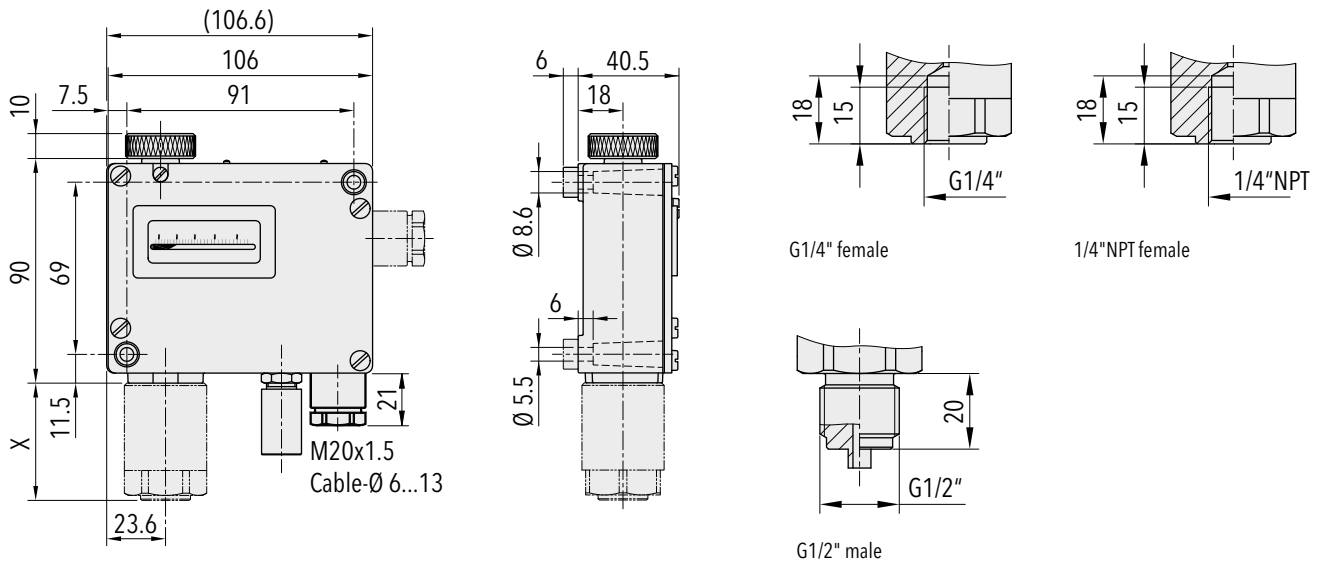

Dimension X and Y see data sheet H72271

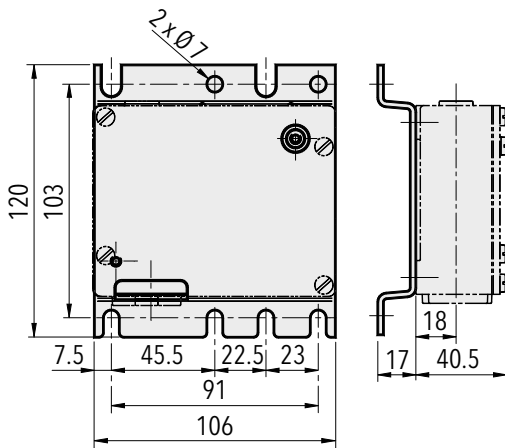
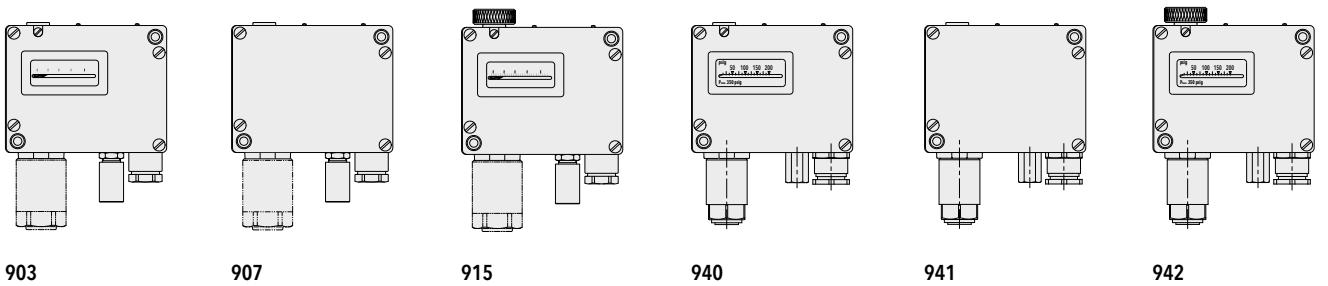

9XX.XX.XX.XXX.31.XX

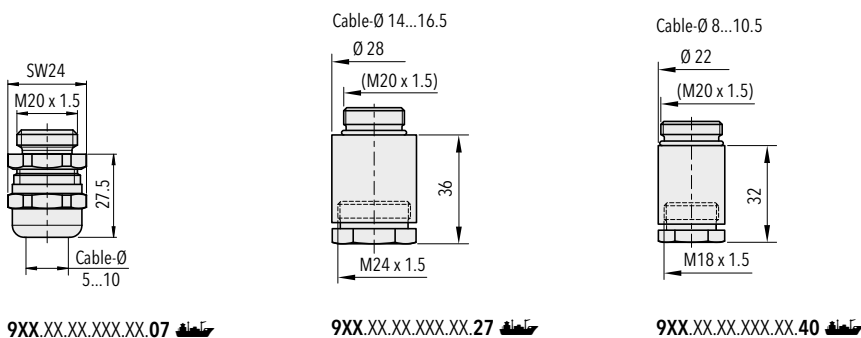

9XX.XX.XX.XXX.XX.07

9XX.XX.XX.XXX.XX.27

9XX.XX.XX.XXX.XX.40

Switching differential typ. @ 25°C

Measuring range of bellows sensor	[bar]	-0.9 ... 1.5	0 ... 4	1 ... 10	2 ... 25
		0.2 ... 1.6	0 ... 6	1 ... 16	4 ... 40
		0.2 ... 2.5			
Adjustable range of switching differential Microswitch 12, 23 (Type 903/907/915)	[bar]	0.1 ... 1.3	0.4 ... 3.2	1 ... 7.5	3 ... 18
Adjustable range of switching differential Microswitch 11, 12, 23 (Type 940/941/942)	[bar]	0.06 ... 0.2	0.2 ... 0.6	0.5 ... 1.6	1 ... 4
Measuring range of bellows sensor	[psi]	5 ... 50	10 ... 100	50 ... 500	
			25 ... 200		
Adjustable range of switching differential Microswitch 12, 23 (Type 903/907/915)	[psi]	6 ... 40	15 ... 105	45 ... 260	
Adjustable range of switching differential Microswitch 11, 12, 23 (Type 940/941/942)	[psi]	3 ... 8	8 ... 20	15 ... 55	

Electrical data switch

Type	Features	Rating	
		Resistive Load (Inductive Load)	
		AC	DC
11*)	Average switching differential	125 V, 15 (1.5) A 250 V, 15 (1.25) A 500 V, 10 (0.75) A	250 V, 0.25 (0.03) A 125 V, 0.5 (0.05) A 30 V, 6 (1.5) A 14 V, 15 (1.5) A
12	High vibration resistance; average switching differential	125 V, 15 (1.5) A 250 V, 15 (1.25) A 500 V, 10 (0.75) A	250 V, 0.3 (0.2) A 125 V, 0.75 (0.4) A 30 V, 15 (1.5) A 14 V, 15 (1.5) A
23	Increased vibration resistance; average switching differential	125 V, 15 (1.5) A 250 V, 15 (1.25) A 500 V, 10 (0.75) A	250 V, 0.3 (0.2) A 125 V, 0.6 (0.4) A 30 V, 15 (1.5) A 14 V, 15 (1.5) A

*1) Switch 11 only with type No. 940, 941, 942

Electrical Connection

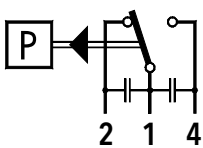

Switch **11/12/23**

PRESSOSTAT

Swiss based Trafag is a leading international supplier of high quality sensors and monitoring instruments for measurement of pressure and temperature.



Applications

- Shipbuilding
- Engine manufacturing
- Railways
- Machine tools
- Hydraulics





Features

- Rugged aluminium housing
- Protection IP65
- Any mounting position possible

Technical Data			
Measuring principle	Piston	Repeatability	± 1.0 % FS typ.
Measuring range	1 ... 10 to 60 ... 600 bar	Media temperature	O-Ring NBR: -30°C ... +100°C O-Ring FKM: -15°C ... +150°C
Output signal	1 Floating change-over contact (SPDT)	Ambient temperature	-20°C ... +70°C
Switching differential	Not adjustable	Approval / conformity	ABS, BV, CCS, DNV, GL, KRS, LRS, RINA EN60730-1/ EN60730-2-6: Typ 2.B.H

Subject to change

Ordering information/type code

		XXX	XX	XX	XXX	XX	XX			
Custom build code	With display and adjusting screw	944								
	Without display, with adjusting screw	947								
Microswitch	Small switching differential, standard vibration resistance ^{1) 2)}		10							
	Average switching differential, standard vibration resistance ¹⁾		11							
	Average switching differential, increased vibration resistance  ¹⁾		23							
	Large switching differential, high vibration resistance  ¹⁾		26							
	With gold plated contacts, standard vibration resistance ¹⁾		21							
Range	Range [bar]	Over pressure [bar]	Burst pressure [bar]		Range [bar]	Over pressure [bar]	Burst pressure [bar]			
	1 ... 10	100	200	78	16 ... 160	400	600	84		
	4 ... 40	200	400	81	25 ... 250	400	600	85		
	6 ... 60	200	400	82	40 ... 400	800	1000	86		
	10 ... 100	200	400	83	60 ... 600	800	1000	87		
Sensor	Sensor material	Sensor housing material	Thread	Range		Sensor material	Sensor housing material	Thread	Range	
	1.4435, O-ring NBR	1.4435	G1/4" female	78	700	1.4435, O-ring NBR	1.4435	G1/2" male	82, 83	710
	1.4435, O-ring FKM	1.4435	G1/4" female	78	701	1.4435, O-ring FKM	1.4435	G1/2" male	82, 83	711
	1.4435, O-ring NBR	1.4435	G1/2" male	78	702	1.4435, O-ring NBR	1.4435	G1/4" female	84, 85	712
	1.4435, O-ring FKM	1.4435	G1/2" male	78	703	1.4435, O-ring FKM	1.4435	G1/4" female	84, 85	713
	1.4435, O-ring NBR	1.4435	G1/4" female	81	704	1.4435, O-ring NBR	1.4435	G1/2" male	84, 85	714
	1.4435, O-ring FKM	1.4435	G1/4" female	81	705	1.4435, O-ring FKM	1.4435	G1/2" male	84, 85	715
	1.4435, O-ring NBR	1.4435	G1/2" male	81	706	1.4435, O-ring NBR	1.4435	G1/4" female	86, 87	722
	1.4435, O-ring FKM	1.4435	G1/2" male	81	707	1.4435, O-ring FKM	1.4435	G1/4" female	86, 87	723
	1.4435, O-ring NBR	1.4435	G1/4" female	82, 83	708	1.4435, O-ring NBR	1.4435	G1/2" male	86, 87	724
	1.4435, O-ring FKM	1.4435	G1/4" female	82, 83	709	1.4435, O-ring FKM	1.4435	G1/2" male	86, 87	725
	Fixing	Direct on sensor or housing								00
		With mounting bracket								31
	Accessories	Lead seal (manipulation protection)								16
		Screwed cable gland M20x1.5 (EN50262) 								07
Screwed cable gland M24x1.5 (DIN89280) 									27	
Screwed cable gland M18x1.5 (DIN89280) 									40	
Damping elements and snubber see data sheet H72258										

¹⁾ Switching differential not adjustable

²⁾ Not suitable for applications under vibration

Standard products (extra short lead time)

Product No.	Type Code	Pressure range [bar]	Over pressure max. [bar]	Switching differential [bar]	Diameter Y [mm]	Length X [mm]
PK10	944 2378 700	1 ... 10	100	0.45 ... 0.9 (fix)	33	47
PK40	944 2381 704	4 ... 40	200	1.8 ... 3.4 (fix)	27	42.5
PK100	944 2383 708	10 ... 100	200	3.2 ... 7.5 (fix)	27	42.5
PK250	944 2385 712	25 ... 250	400	5.2 ... 16 (fix)	27	42.5

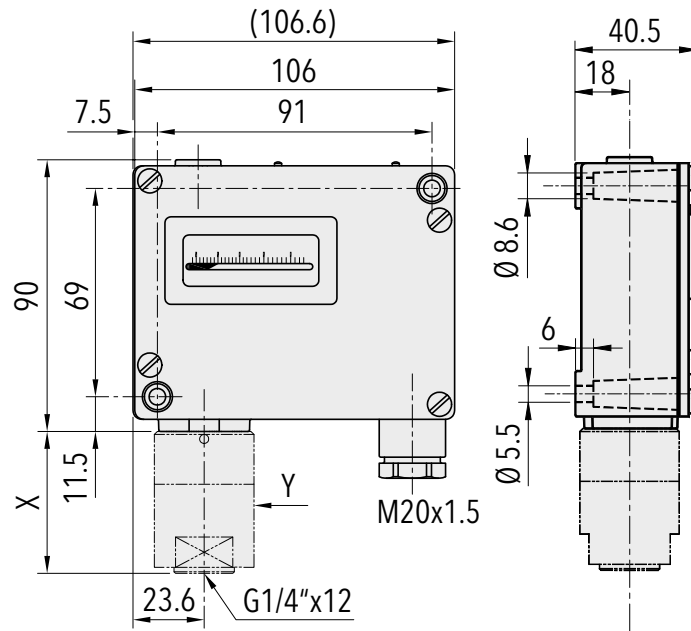

Specifications		
Accuracy	Repeatability	± 1.0 % FS typ.
	Scale accuracy typ.	± 2.0 % FS typ.
	Switching differential	See table
	Adjustment range switchpoint ¹⁾	10% ... 90% FS
Environmental conditions	Ambient temperature	-20°C ... +70°C
	Media temperature	O-Ring NBR: -30°C ... +100°C O-Ring FKM: -15°C ... +150°C
	Storage temperature	-25°C ... +85°C
	Protection	IP65
	Humidity	Max.95 % relative
	Vibration	Switch 23/26: 5...25 Hz: ±1.6 mm 25...100 Hz: 4g
	Shock	50g/ 11ms
Mechanical Data	Sensor	1.4435
	Housing	AlSi10Mg/ Epoxy coated
	Sealing	NBR/FKM
	Screwed cable gland	Brass nickel plated
	Mounting torque	Max. 25 Nm
	Installation	any position
	Weight	~ 710 g
Microswitch	Rating	See table
	Resistance of insulation	500 VDC / 100 MΩ
	Dielectric strength	U ≤ 250V: 1.45 kV / U ≤ 500V: 2 kV terminal ground
	Life time (mechanical)	Microswitch 10/11: 20 Mio. cycles Microswitch 21: 0.5 Mio. cycles Microswitch 23/26: 0.3 Mio. cycles
Electrical connection	Electrical connections	Terminal screw
	Cable gland	M20x1.5 Cable-Ø 6...13 mm
	Terminal screw	3 x 1.5...4 mm ²

¹⁾ Other adjustment ranges upon request

Additional information		
Documents	Data sheet	www.trafag.com/H72259
	Instructions	www.trafag.com/H71261
	Flyer	www.trafag.com/H70912

Dimensions

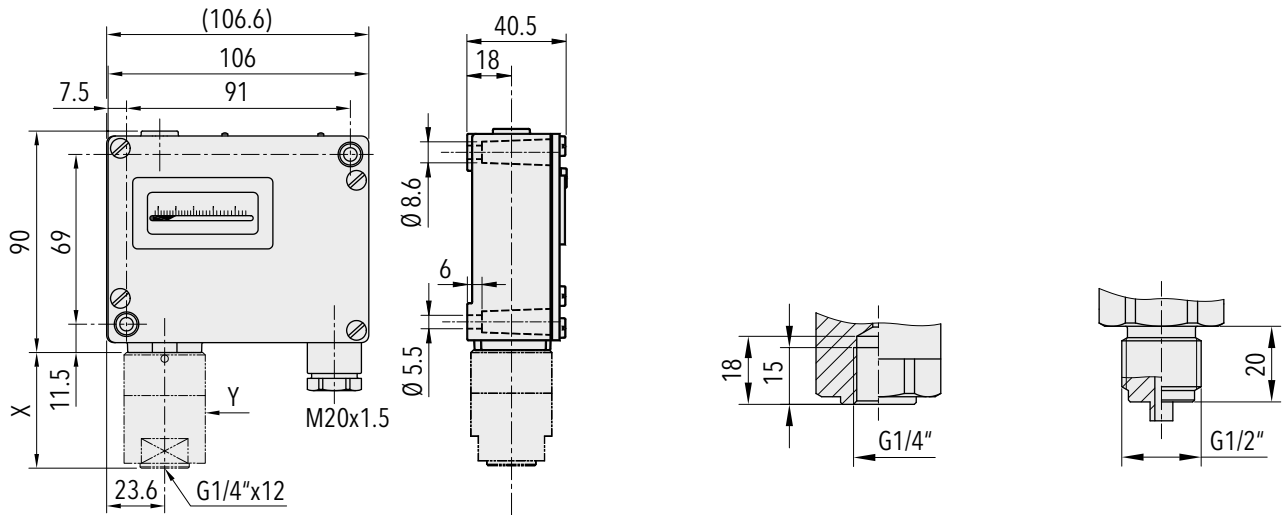

Dimension X and Y see data sheet H72271

G1/4" female

G1/2" male

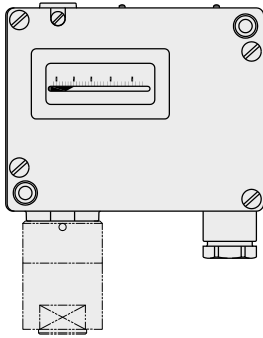

944.XX.XX.XXX.XX.XX

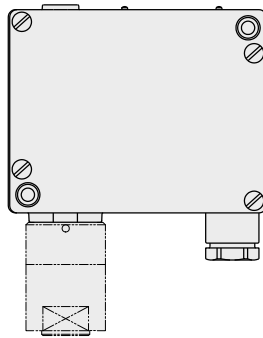

947.XX.XX.XXX.XX.XX

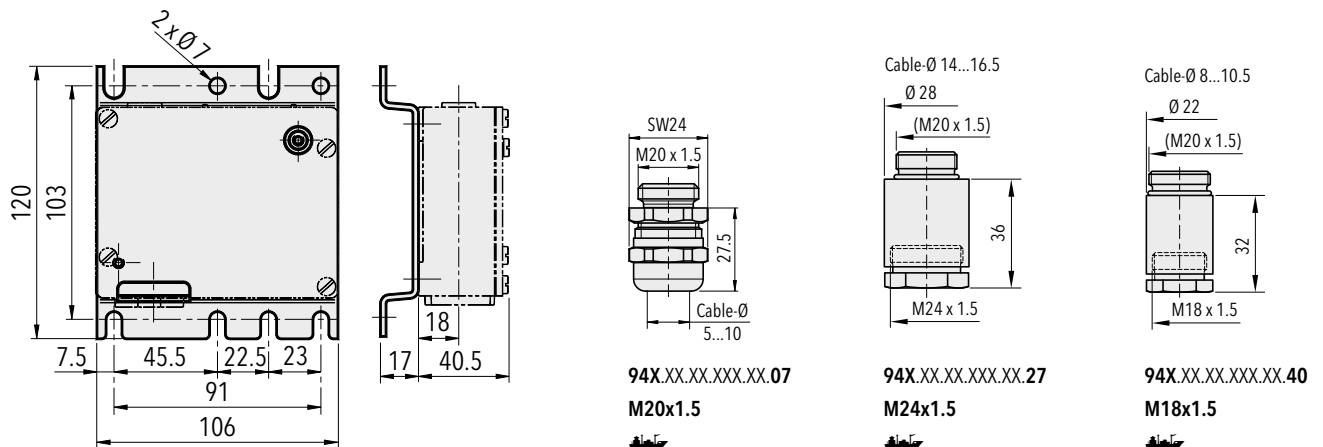

94X.XX.XX.XXX.31.XX

94X.XX.XX.XXX.XX.07
M20x1.5



94X.XX.XX.XXX.XX.27
M24x1.5

94X.XX.XX.XXX.XX.40
M18x1.5

Switching differential typ. @ 25°C

Measuring range of piston sensor	[bar]	1 ... 10	4 ... 40	6 ... 60	10 ... 100	16 ... 160	25 ... 250	40 ... 400	60 ... 600
Microswitch 10 Switching differential (not adjustable, variable according to set point)	[bar]	0.4 ... 0.8	1.5 ... 2.5	2.0 ... 3.7	2.6 ... 5.5	3.4 ... 8.0	4.3 ... 11	5.3 ... 16	6.5 ... 21
Microswitch 11, 21, 23 Switching differential (not adjustable, variable according to set point)	[bar]	0.45 ... 0.9	1.8 ... 3.4	2.3 ... 4.8	3.2 ... 7.5	4.1 ... 11	5.2 ... 16	6.5 ... 23	8.0 ... 32
Microswitch 26 Switching differential (not adjustable, variable according to set point)	[bar]	0.55 ... 1.1	2.0 ... 4.0	2.7 ... 5.7	3.7 ... 9.0	4.7 ... 13	6.0 ... 19	7.5 ... 28	9.0 ... 38

Electrical data switch

Type	Features	Rating	
		Resistive Load (Inductive Load)	
		AC	DC
10	Small switching differential (not recommended for applications under vibrations)	125 V, 10 (1.5) A 250 V, 10 (1.25) A	250 V, 0.2 (0.02) A 125 V, 0.4 (0.03) A 30 V, 2 (1) A 14 V, 15 (2.5) A
11	Average switching differential, standard vibration resistance	125 V, 15 (1.5) A 250 V, 15 (1.25) A 500 V, 10 (0.75) A	250 V, 0.25 (0.03) A 125 V, 0.5 (0.05) A 30 V, 6 (1.5) A 14 V, 15 (1.5) A
23 	Average switching differential, increased vibration resistance	125 V, 15 (1.5) A 250 V, 15 (1.25) A 500 V, 10 (0.75) A	250 V, 0.3 (0.05) A 125 V, 0.6 (0.1) A 30 V, 15 (1.5) A 14 V, 15 (1.5) A
26 	Large switching differential, high vibration resistance	125 V, 15 (1.5) A 250 V, 15 (1.25) A 500 V, 10 (0.75) A	250 V, 0.3 (0.2) A 125 V, 0.75 (0.4) A 30 V, 15 (1.5) A 14 V, 15 (1.5) A
21	With gold plated contacts, standard vibration resistance	24 V, 0.1 (0.1) A 12 V, 1 (1.0) A 5 V, 2 (2.0) A	24 V, 0.1 (0.1) A 12 V, 1 (1.0) A 5 V, 2 (2.0) A

Electrical Connection

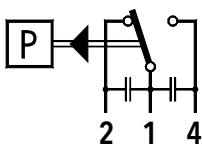

Switch 11/12/23

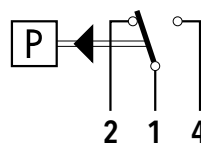

Switch 26

DIFFERENTIAL PRESSURE PRESSOSTAT

Swiss based Trafag is a leading international supplier of high quality sensors and monitoring instruments for measurement of pressure and temperature.



Applications

- Shipbuilding
- Engine manufacturing
- Railways
- Machine tools
- Hydraulics



Features

- Rugged aluminium housing
- Protection IP65
- Any mounting position possible

Technical Data			
Measuring principle	Bellow	Repeatability	± 1.0 % FS typ.
Measuring range	-1 ... 6 to -1 ... 18 bar	Media temperature	-40°C ... +150°C
Differential pressure	-0.6 ... 3.4 to 1 ... 16 bar	Ambient temperature	-25°C ... +70°C
Output signal	1 Floating change-over contact (SPDT)	Approval / conformity	ABS, BV, CCS, DNV-GL, KRS, LRS, RINA EN60730-1/ EN60730-2-6: Typ 2.B.H
Switching differential	Not adjustable		

Subject to change

Ordering information/type code

		XXX	XX	XX	XXX	XX	XX	
Custom build code	With display and adjusting screw	920						
	Without display, with adjusting screw	924						
	With display and adjusting knob	932						
Microswitch	Small switching differential, standard vibration resistance ^{1) 2)}		10					
	Average switching differential, standard vibration resistance ¹⁾		11					
	Average switching differential, increased vibration resistance  ¹⁾		23					
	Large switching differential, high vibration resistance  ¹⁾		26					
	With gold plated contacts, standard vibration resistance ¹⁾		21					
Range	Range [bar]	Differential pressure [bar]	Over pressure [bar]	Burst pressure [bar]				
	-1 ... 6	-0.6 ... 3.4	12	26			74	
	-1 ... 6	0 ... 4	12	26			76	
	-1 ... 8	0 ... 6	12	26			77	
	-1 ... 12	1 ... 10	24	36			78	
	-1 ... 18	1 ... 16	24	36			79	
Sensor	Sensor material	Sensor housing material	Range	Thread				
	Bellows: 1.4435, medium contact. parts 1.4435	Brass nickel plated	74	G1/4" female			830	
	Bellows: 1.4435, medium contact. parts 1.4435	Brass nickel plated	74	G1/8" female			831	
	Bellows: 1.4435, medium contact. parts 1.4435	Brass nickel plated	74	G1/2" male			832	
	Bellows: 1.4435, medium contact. parts 1.4435	Brass nickel plated	76, 77	G1/8" female			833	
	Bellows: 1.4435, medium contact. parts 1.4435	Brass nickel plated	76, 77	G1/2" male			834	
	Bellows: 1.4435, medium contact. parts 1.4435	Brass nickel plated	76, 77	G1/4" female			837	
	Bellows: 1.4435, medium contact. parts 1.4435	Brass nickel plated	78, 79	G1/8" female			835	
	Bellows: 1.4435, medium contact. parts 1.4435	Brass nickel plated	78, 79	G1/2" male			836	
	Bellows: 1.4435, medium contact. parts 1.4435	Brass nickel plated	78, 79	G1/4" female			838	
	Bronze	Brass	74	G1/4" female			930	
	Bronze	Brass	74	G1/8" female			931	
	Bronze	Brass	74	G1/2" male			932	
	Bronze	Brass	76, 77	G1/8" female			933	
	Bronze	Brass	76, 77	G1/2" male			934	
	Bronze	Brass	76, 77	G1/4" female			937	
	Bronze	Brass	78, 79	G1/8" female			935	
	Bronze	Brass	78, 79	G1/2" male			936	
	Bronze	Brass	78, 79	G1/4" female			938	
	Bronze	Brass chemically nickel plated	74	G1/4" female			980	
	Bronze	Brass chemically nickel plated	74	G1/8" female			981	
	Bronze	Brass chemically nickel plated	74	G1/2" male			982	
	Bronze	Brass chemically nickel plated	76, 77	G1/8" female			983	
	Bronze	Brass chemically nickel plated	76, 77	G1/2" male			984	
	Bronze	Brass chemically nickel plated	76, 77	G1/4" female			987	
	Bronze	Brass chemically nickel plated	78, 79	G1/8" female			985	
	Bronze	Brass chemically nickel plated	78, 79	G1/2" male			986	
	Bronze	Brass chemically nickel plated	78, 79	G1/4" female			988	
	Fixing	Direct on sensor or housing						00
		By mounting bracket						31

Accessories		
Lead seal (manipulation protection)		16
Screwed cable gland M20x1.5 (EN50262)		07
Screwed cable gland M24x1.5 (DIN89280)		27
Screwed cable gland M18x1.5 (DIN89280)		40
Adapter G1/8" male - G1/2" male, Brass		A6
Adapter G1/8" male - G1/2" male, Brass nickel plated		B6
Adapter G1/8" male - G1/2" male, Stainless steel 1.4435		D6
Adapter G1/8" male - G1/4" female, Brass		A5
Adapter G1/8" male - G1/4" female, Brass nickel plated		B5
Adapter G1/8" male - G1/4" female, Stainless steel 1.4435		D5
Damping elements and snubber see data sheet H72258		

¹⁾ Switching differential not adjustable

²⁾ Not suitable for applications under vibration

Standard products (extra short lead time)

Product No.	Type Code	Pressure range [bar]	Differential pressure [bar]	Over pressure max. [bar]	Switching differential [bar]	Length X [mm]
PD3.4	920 2374 931	-1 ... +6	-0.6 ... +3.4	12	0.16 (fixed)	77
PD6	920 2377 933	-1 ... +8	0 ... 6	12	0.16 (fixed)	77
PD16	920 2379 935	-1 ... 18	1 ... 16	24	0.4 (fixed)	87

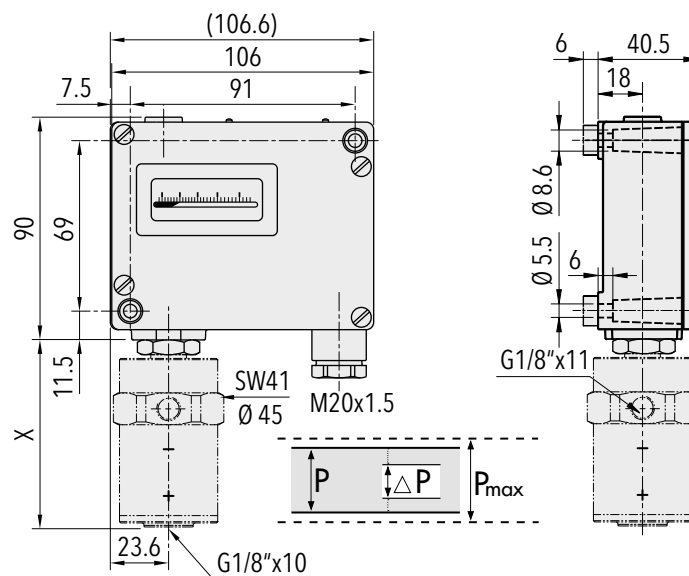

Specifications		
Accuracy	Repeatability	± 1.0 % FS typ.
	Scale accuracy typ.	± 2.0 % FS typ.
	Switching differential	See table
	Adjustment range switchpoint ¹⁾	10% ... 90% FS
Environmental conditions	Ambient temperature	-25°C ... +70°C
	Media temperature	-40°C ... +150°C
	Storage temperature	-25°C ... +85°C
	Protection	IP65
	Humidity	Max. 95 % relative
	Vibration	Switch 23/26: 5...25 Hz: ±1.6 mm 25...100 Hz: 4g
	Shock	50g/ 11ms
Mechanical Data	Sensor	See ordering information
	Housing	AlSi10Mg/ Epoxy coated
	Sealing	NBR
	Screwed cable gland	Brass nickel plated
	Mounting torque	Max. 25 Nm
	Installation	any position
	Weight	~ 610 g
Microswitch	Rating	See table
	Resistance of insulation	> 2 MΩ
	Dielectric strength	U ≤ 250V: 1.45 kV/ U ≤ 500V: 2 kV terminal ground
	Life time (mechanical)	Microswitch 10/11: 20 Mio. cycles Microswitch 21: 0.5 Mio. cycles Microswitch 23/26: 0.3 Mio. cycles
Electrical connection	Electrical connections	Terminal screw
	Cable gland	M20x1.5 Cable-Ø 6...13 mm
	Terminal screw	3 x 1.5...4 mm ²



¹⁾ Other adjustment ranges upon request

Additional information		
Documents	Data sheet	www.trafag.com/H72253
	Instructions	www.trafag.com/H73256
	Flyer	www.trafag.com/H70914

Switching differential typ. @ 25°C

Range of piston sensor	[bar]	-1 ... 6 -1 ... 8	-1 ... 12 -1 ... 18
Microswitch 10 Switching differential (not adjustable)	[bar]	0.08	0.2
Microswitch 11/21/23 Switching differential (not adjustable)	[bar]	0.16	0.4
Microswitch 26 Switching differential (not adjustable)	[bar]	0.25	0.5

Electrical data switch

Type	Features	Rating	
		Resistive Load (Inductive Load)	
		AC	DC
10	Small switching differential (not recommended for applications under vibrations)	125 V, 10 (1.5) A 250 V, 10 (1.25) A	250 V, 0.2 (0.02) A 125 V, 0.4 (0.03) A 30 V, 2 (1) A 14 V, 15 (2.5) A
11	Average switching differential, standard vibration resistance	125 V, 15 (1.5) A 250 V, 15 (1.25) A 500 V, 10 (0.75) A	250 V, 0.25 (0.03) A 125 V, 0.5 (0.05) A 30 V, 6 (1.5) A 14 V, 15 (1.5) A
23 	Average switching differential, increased vibration resistance	125 V, 15 (1.5) A 250 V, 15 (1.25) A 500 V, 10 (0.75) A	250 V, 0.3 (0.05) A 125 V, 0.6 (0.1) A 30 V, 15 (1.5) A 14 V, 15 (1.5) A
26 	Large switching differential, high vibration resistance	125 V, 15 (1.5) A 250 V, 15 (1.25) A 500 V, 10 (0.75) A	250 V, 0.3 (0.2) A 125 V, 0.75 (0.4) A 30 V, 15 (1.5) A 14 V, 15 (1.5) A
21	With gold plated contacts, standard vibration resistance	24 V, 0.1 (0.1) A 12 V, 1.0 (1.0) A 5 V, 2.0 (2.0) A	24 V, 0.1 (0.1) A 12 V, 1.0 (1.0) A 5 V, 2.0 (2.0) A

Electrical Connection

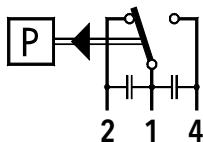

Switch 10/11/23

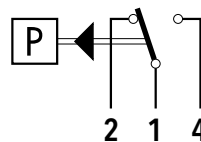

Switch 21/26

PRESSOSTAT

Swiss based Trafag is a leading international supplier of high quality sensors and monitoring instruments for measurement of pressure and temperature.



Applications

- Machine tools
- Medium voltage switchgear

Features

- Steel or bronze bellows
- Blade connector (IEC) 2.8 x 0.5 mm
- Compact design
- Adjustment in factory

Technical Data			
Measuring principle	Bellow	Repeatability	± 1.0 % FS typ.
Measuring range	-0.3 ... 1.3 to 1 ... 10 bar	Media temperature	-25°C ... +80°C
Output signal	1 or 2 floating change-over contacts (SPDT)	Ambient temperature	-25°C ... +70°C
Switching differential	Not adjustable	Approval / conformity	EN60730-1/ EN60730-2-6: Typ 2.B.H
Switching point	Adjustment in factory		

Subject to change

Ordering information/type code

		XXX	XX	XX	XXX	XX	XX	XX	
Custom build code	1 Floating change-over contact (SPDT)	987							
	2 Floating change-over contacts (SPDT)	988							
Microswitch	Standard contacts, switching differential not adjustable		42						
	Gold plated contacts, switching differential not adjustable		84						
Range	Range [bar]	Over pressure [bar]	Burst pressure [bar]						
	-0.3 ... 1.3	-1 ... 4	10				72		
	0 ... 1.6	-1 ... 4	10				73		
	0 ... 2.5	-1 ... 4	10				75		
	0 ... 4	-1 ... 6	10				76		
	1 ... 10	-1 ... 15	15				78		
Sensor	Sensor material	Pressure connection	Range						
	Bellows: 1.4301 (AISI 304)	1.4301 (AISI 304), with groove for O-ring	73, 75				847		
	Bellows: 1.4301 (AISI 304)	1.4301 (AISI 304), with groove for O-ring	76				846		
	Bellows: Bronze (CuSn6)	Brass (CuZn39Pb3), without groove for O-ring	72, 73, 75				947		
	Bellows: Bronze (CuSn6)	Brass (CuZn39Pb3), without groove for O-ring	76				946		
	Bellows: Bronze (CuSn6)	Brass (CuZn39Pb3), without groove for O-ring	78				945		
	Bellows: Bronze (CuSn6)	Brass (CuZn39Pb3), with groove for O-ring	72, 73, 75				949		
	Bellows: Bronze (CuSn6)	Brass (CuZn39Pb3), with groove for O-ring	76				948		
	Bellows: Bronze (CuSn6)	Brass (CuZn39Pb3), with groove for O-ring	78				939		
Code number	Specified by Trafag							XX	
Fixing	Direct on sensor or housing							00	
Accessories	Blade receptacle (2.8 x 0.5 mm) and insulator for flat plugs (2 x 6 pcs.)							09	
	Switchpoint fixed and sealed upon customer's request							88	
	Switchpoint preset upon customer's request, no guarantee on switching accuracy							83	
	Switchpoint adjustment switch I (lower switchpoint) and switch II (upper switchpoint)								
	Please indicate for each switch when ordering: - Switchpoint [bar] - Increasing or decreasing								
	Routine test of leakage rate <math> < 10^{-7}</math> mbar-l/s								05
Damping elements and snubber see data sheet H72258									

Specifications		
Accuracy	Repeatability	± 1.0 % FS typ.
	Switching differential	See table
	Adjustment range switchpoint ¹⁾	10% ... 90% FS
Environmental conditions	Ambient temperature	-25°C ... +70°C
	Media temperature	-25°C ... +80°C
	Storage temperature	-40°C ... +80°C
	Protection	IP40 (Microswitch IP67)
	Humidity	Max. 95 % relative
	Vibration	5 ... 100 Hz: 2 g
	Shock	50g/ 11ms
Mechanical Data	Sensor	See ordering information
	Housing	PBTP, Crastin
	Sealing	-
	Mounting torque	Max. 25 Nm
	Installation	any position
	Weight	~ 110 g
	Microswitch	Rating
Resistance of insulation		> 2 MΩ, 500 VDC
Dielectric strength		2 kV terminal ground
Life time (mechanical)		2 Mio. cycles
Electrical connection	Electrical connections	Blade connector
	Blade connector	IEC 2.8 x 0.5 mm 0.75...1 mm ²

¹⁾ Pressure range 1 ... 10 bar; Max. 2 bar switchpoint difference between switch I and switch II
Other adjustment ranges upon request

Additional information		
Documents	Data sheet	www.trafag.com/H72272
	Instructions	www.trafag.com/H73272
	Flyer	www.trafag.com/H70915

Dimensions

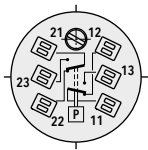
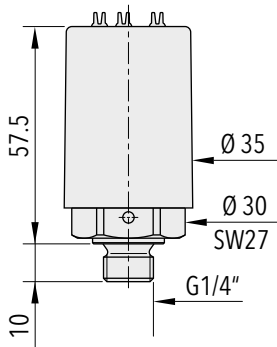

98X.XXXX.945/946/947

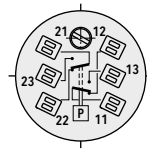
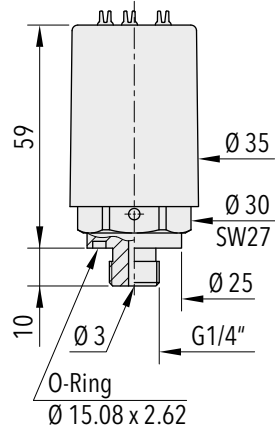

98X.XXXX.939/948/949

(O-Ring not included in delivery)

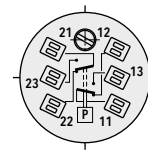
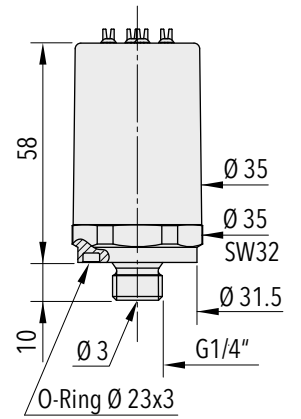

98X.XXXX.846/847

(O-Ring not included in delivery)

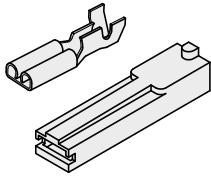

98X.XXXX.XXX.XX.XX.09

Switching differential typ. @ 25°C

Measuring range of bellows sensor	[bar]	-0.3 ... 1.3	0 ... 1.6	0 ... 2.5	0 ... 4	1 ... 10
Microswitch 42/84 Switching differential (not adjustable)	[bar]	0.1	0.1	0.2	0.3	0.6
Tolerance of setting	[bar]	±0.08	±0.08	±0.12	±0.16	±0.2

Electrical data switch

Type	Features	Rating	
		Resistive Load (Inductive Load)	
		AC	DC
42 (Standard)	Silver contacts	250 V, 6 (1) A	220 V, 0.25 (0.1) A 110 V, 0.5 (0.2) A 60 V, 1(0.5) A 24 V, 3 (2) A 12 V, 6 (6) A
84	Gold plated contacts, suitable for intrinsically safe control circuits	max. 30 V, 0.1 (0.1) A min. 5 V, 5 mA	

Electrical connection

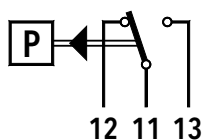

987

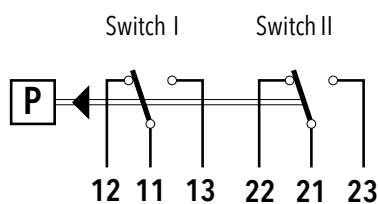

988

MEMBRANE PRESSOSTAT

Swiss based Trafag is a leading international supplier of high quality sensors and monitoring instruments for measurement of pressure and temperature.



Applications

- Machine tools
- HVAC

Features

- Rugged aluminium housing
- Protection IP65
- Any mounting position possible

Technical Data			
Measuring principle	Membrane	Repeatability	± 1.0 % FS typ.
Measuring range	0.02 ... 0.25 to 0.05 ... 1 bar	Media temperature	-40°C ... +150°C
Output signal	1 Floating change-over contact (SPDT)	Ambient temperature	-25°C ... +70°C
Switching differential	Not adjustable	Approval / conformity	EN60730-1/ EN60730-2-6: Typ 2.B.H

Subject to change

Ordering information/type code

		XXX	XX	XX	XXX	XX	XX
Custom build code	With display and adjusting screw	900					
	Without display, with adjusting screw	904					
	With display and adjusting knob	912					
Microswitch	Small switching differential, standard vibration resistance ¹⁾		10				
	Average switching differential, standard vibration resistance ¹⁾		11				
	Average switching differential, increased vibration resistance ¹⁾		23				
	Large switching differential, high vibration resistance ¹⁾		26				
	With gold plated contacts, standard vibration resistance ¹⁾		21				
Range	Range [bar]	Over pressure [bar]	Burst pressure [bar]				
	0.02 ... 0.25	2	4			46	
	0.03 ... 0.4	2	4			47	
	0.04 ... 0.6	4	7.5			48	
	0.05 ... 1.0	4	7.5			49	
Sensor	Sensor material	Sensor housing material	Thread	Range			
	EFFBE	Anodized aluminium	G1/4" female	46, 47		740	
	EFFBE	Anodized aluminium	G1/2" male	46, 47		741	
	EFFBE	Anodized aluminium	G1/4" female	48, 49		742	
	EFFBE	Anodized aluminium	G1/2" male	48, 49		743	
Fixing	Direct on sensor or housing						00
Accessories	Lead seal (manipulation protection)						16
	Screwed cable gland M24x1.5 (DIN89280)						27
	Screwed cable gland M18x1.5 (DIN89280)						40

¹⁾ Switching differential not adjustable

Specifications		
Accuracy	Repeatability	± 1.0 % FS typ.
	Scale accuracy typ.	± 2.0 % FS typ.
	Switching differential	See table
	Adjustment range switchpoint ²⁾	10% ... 90% FS
Environmental conditions	Ambient temperature	-25°C ... +70°C
	Media temperature	-40°C ... +150°C
	Storage temperature	-25°C ... +85°C
	Protection	IP65
	Humidity	Max. 95 % relative
	Vibration	Switch 23/26: 5...25 Hz: ±1.6 mm 25...100 Hz: 4g
	Shock	50g/ 11ms
Mechanical Data	Sensor ¹⁾	Anodized aluminium, EFFBE
	Housing	AlSi10Mg/ Epoxy coated
	Sealing	NBR
	Screwed cable gland	Brass nickel plated
	Mounting torque	Max. 25 Nm
	Installation	any position
	Weight	~ 850 g
Microswitch	Rating	See table
	Resistance of insulation	> 2 MΩ
	Dielectric strength	U ≤ 250V: 1.45 kV / U ≤ 500V: 2 kV terminal ground
	Life time (mechanical)	Microswitch 10/11: 20 Mio. cycles Microswitch 21: 0.5 Mio. cycles Microswitch 23/26: 0.3 Mio. cycles
Electrical connection	Electrical connections	Terminal screw
	Cable gland	M20x1.5 Cable-Ø 6...13 mm
	Terminal screw	3 x 0.5...4 mm ²

¹⁾ Membrane: EFFBE

Resistance: Acetylene, Hydrogen, Natural gas, Propane, Sea water, Glycols, Sulphur Dioxide, Water, Butane, Methane, Diesel

²⁾ Other adjustment ranges upon request

Additional information

Documents		
Data sheet		www.trafag.com/H72262
Flyer		www.trafag.com/H70918

Dimensions

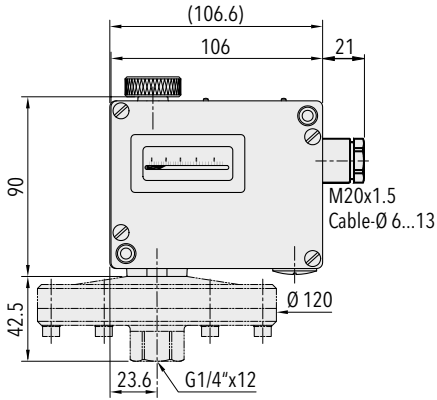

912.XX46/47.740

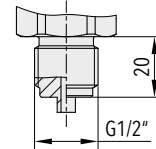
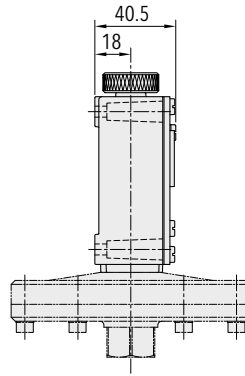

G1/2" mâle

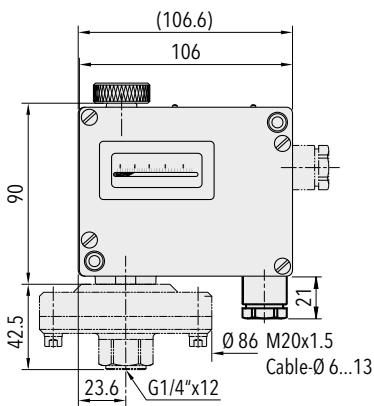

912.XX48/49.742

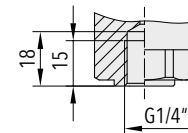
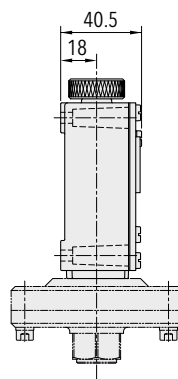

G1/4" femelle

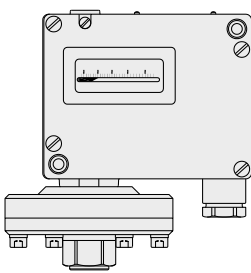

900

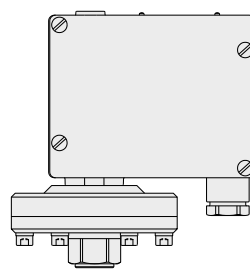

904

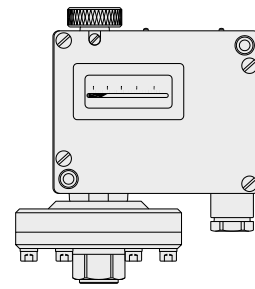

912

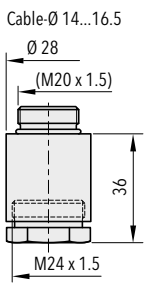

9XX.XX.XX.XXX.XX.27
M24x1.5

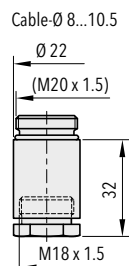

9XX.XX.XX.XXX.XX.40
M18x1.5

Switching differential typ. @ 25°C

Measuring range of bellows sensor	[bar]	0.02 ... 0.25	0.03 ... 0.4	0.04 ... 0.6	0.05 ... 1.0
Microswitch 10 Switching differential (not adjustable)	[bar]	2	2	6	6
Microswitch 11/21/23 Switching differential (not adjustable)	[bar]	5	5	15	15
Microswitch 26 Switching differential (not adjustable)	[bar]	10	10	35	35

Electrical data switch

Type	Features	Rating	
		Resistive Load (Inductive Load)	
		AC	DC
10	Small switching differential (not recommended for applications under vibrations)	125 V 10 (1.5) A 250 V 10 (1.25) A	250 V 0.2 (0.02) A 125 V 0.4 (0.03) A 30 V 2 (1) A 14 V 15 (2.5) A
11	Average switching differential, standard vibration resistance	125 V 15 (1.5) A 250 V 15 (1.25) A 500 V 10 (0.75) A	250 V 0.25 (0.03) A 125 V 0.5 (0.05) A 30 V 6 (1.5) A 14 V 15 (1.5) A
23	Average switching differential, increased vibration resistance	125 V 15 (1.5) A 250 V 15 (1.25) A 500 V 10 (0.75) A	250 V 0.3 (0.05) A 125 V 0.6 (0.1) A 30 V 15 (1.5) A 14 V 15 (1.5) A
26	Large switching differential, high vibration resistance	125 V 15 (1.5) A 250 V 15 (1.25) A 500 V 10 (0.75) A	250 V 0.3 (0.2) A 125 V 0.75 (0.4) A 30 V 15 (1.5) A 14 V 15 (1.5) A
21	With gold plated contacts, standard vibration resistance	24 V 0.1 (0.1) A 12 V 1.0 (1.0) A 5 V 2.0 (2.0) A	24 V 0.1 (0.1) A 12 V 1.0 (1.0) A 5 V 2.0 (2.0) A

Electrical connection

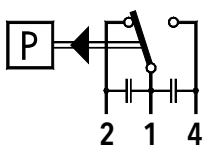

Switch 10/11/23

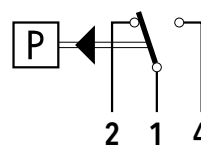

Switch 21/26

EX PRESSOSTAT

Swiss based Trafag is a leading international supplier of high quality sensors and monitoring instruments for measurement of pressure and temperature.



Applications

- Ex II 2 G / D

Features

- Rugged aluminium housing, option: housing stainless steel
- Protection IP66
- Any mounting position possible
- Ex db eb IIC T6 Gb
- Ex tb IIIC T80°C Db

Technical Data			
Measuring principle	Bellow	Media temperature	-40°C ... +150°C
Measuring range	-0.9 ... 1.5 to 4 ... 40 bar	Ambient temperature	-50°C ... +65°C
Output signal	1 Floating change-over contact (SPDT)	Approval / conformity	SEV 15 ATEX 0157 X IECEX SEV 17.0013X
Switching differential	Not adjustable	Type of protection	Areas with gaz explosion hazards: II 2 G Ex db eb IIC T6 Gb Areas with dust explosion hazards: II 2 D Ex tb IIIC T80°C Db
Repeatability	± 1.0 % FS typ.		

Subject to change

Ordering information/type code

		XXX	XX	XX	XXX	XX	XX			
Custom build code	With display and adjusting screw	900								
	Without display, with adjusting screw	904								
	With display and adjusting knob	912								
Microswitch	Standard, not adjustable		91							
Range	Range [bar]	Over pressure [bar]	Burst pressure [bar]		Range [bar]	Over pressure [bar]	Burst pressure [bar]			
	-0.9 ... 1.5	10	13	72	1 ... 10	24	36			
	0.2 ... 1.6	10	13	73	1 ... 16	24	36			
	0.2 ... 2.5	10	13	75	2 ... 25	40	75			
	0 ... 4	12	26	76	4 ... 40	40	75			
	0 ... 6	12	26	77						
Sensor	Sensor material	Sensor housing material	Thread	Range		Sensor material	Sensor housing material	Thread	Range	
	1.4435	Brass nickel plated	G1/4" female	72	850	1.4435	Brass nickel plated	G1/2" male	76, 77	
	1.4435	Brass nickel plated	G1/2" male	72	859	1.4435	Brass nickel plated	G1/4" female	78, 79	
	1.4435	Brass nickel plated	G1/4" female	73, 75	851	1.4435	Brass nickel plated	G1/2" male	78, 79	
	1.4435	Brass nickel plated	G1/2" male	73, 75	852	1.4435	Brass nickel plated	G1/4" female	80, 81	
	1.4435	Brass nickel plated	G1/4" female	76, 77	853	1.4435	Brass nickel plated	G1/2" male	80, 81	
Fixing	Direct on sensor or housing								00	
	With mounting bracket								31	
Accessories	Housing stainless steel								06	
	Damping elements and snubber see data sheet H72258									

Standard products (extra short lead time)

Product No.	Type Code	Pressure range [bar]	Over pressure max. [bar]	Switching differential [bar]	Diameter Y [mm]	Length X [mm]
EXP1.5	900 9172 850 00 0000 0000 02	-0.9 ... 1.5	10	0.2 (fixed)	45	56.5
EXP2.5	900 9175 851 00 0000 0000 02	0.2 ... 2.5	10	0.2 (fixed)	45	56.5
EXP6	900 9177 853 00 0000 0000 02	0 ... 6	12	0.4 (fixed)	33	47
EXP16	900 9179 855 00 0000 0000 02	1 ... 16	24	0.9 (fixed)	27	42.5

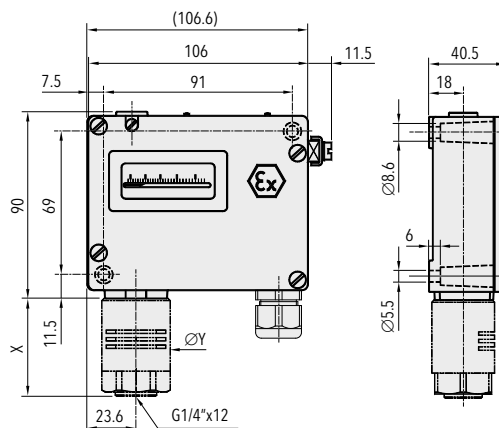

Specifications		
Accuracy	Repeatability	± 1.0 % FS typ.
	Scale accuracy typ.	± 2.0 % FS typ.
	Switching differential	See table
	Adjustment range switchpoint ¹⁾	10% ... 90% FS
Environmental conditions	Ambient temperature	-50°C ... +65°C
	Media temperature	-40°C ... +150°C
	Storage temperature	-50°C ... +65°C
	Protection	IP66 Accessory 06: IP66
	Humidity	Max.95 % relative
	Vibration	5...25 Hz: ±1.6 mm 25...100 Hz: 4g Ranges 72, 73, 75: 5...50 Hz: 20 mm/sec.
	Shock	50g/ 11ms
Mechanical Data	Sensor	See ordering information
	Housing	AlSi10Mg/ Epoxy coated Accessory 06: 1.4301 (AISI 304)
	Sealing	NBR
	Screwed cable gland	Polyamide
	Mounting torque	Max. 25 Nm
	Installation	any position
	Weight	~ 710 g
Microswitch	Rating	See table
	Resistance of insulation	> 2 MΩ
	Dielectric strength	1.5 kV
	Life time (mechanical)	1 Mio. cycles
Electrical connection	Electrical connections	Terminal screw
	Cable gland	M20x1.5/SW24 Cable-Ø 5.5-13 mm Approval: PTB 99 ATEX 3128 X
	Terminal screw	3 x 0.5...1.5 mm ²

¹⁾ Other adjustment ranges upon request

Additional information		
Documents	Data sheet	www.trafag.com/H72263
	Instructions	www.trafag.com/H73171
	Flyer	www.trafag.com/H70916

Dimensions

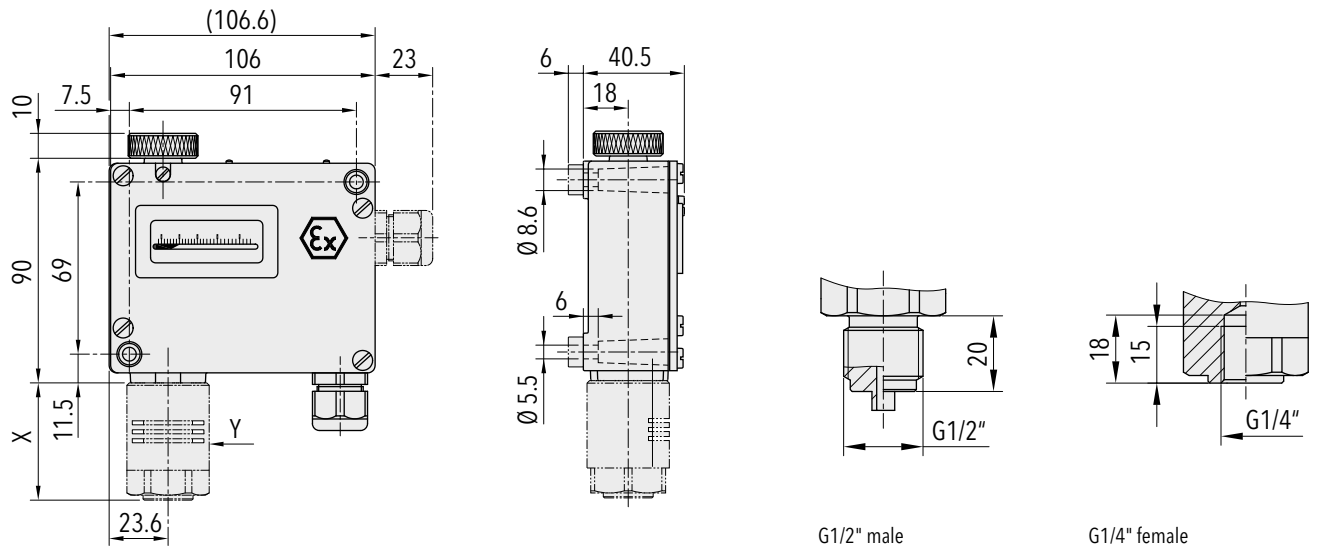

Dimension X and Y see data sheet H72271

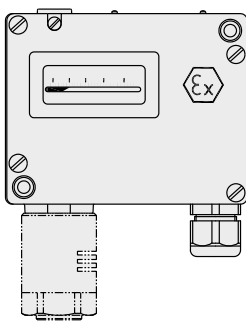

900

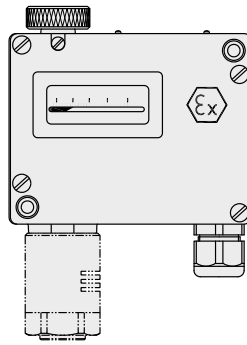

912

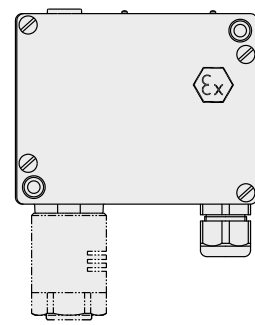

904

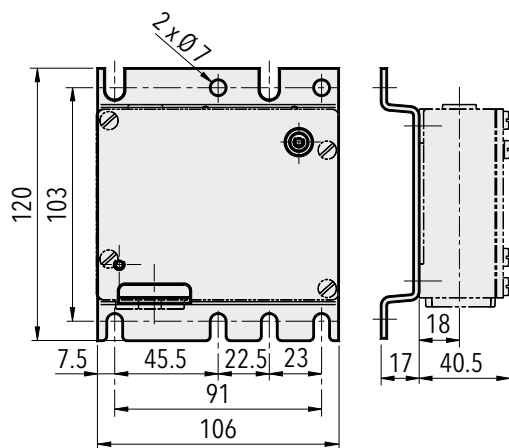

9XX.XXXX.XXX.31

Switching differential typ. @ 25°C

Measuring range of bellows sensor	[bar]	-0.9 ... 1.5	0 ... 4	1 ... 10	2 ... 25
		0.2 ... 1.6	0 ... 6	1 ... 16	4 ... 40
		0.2 ... 2.5			
Microswitch 91	[bar]	0.2	0.4	0.9	2.0
Switching differential (not adjustable)					

Electrical data switch

Type	Features	Rating	
		Resistive Load (Inductive Load)	
		AC	DC
91	Standard Ex	250V 5(5) A 125V 5(5) A	250 V 0.25 (0.03) A 125 V 0.5 (0.06) A 75 V 0.75 (0.25) A 50 V 1 (1) A 30 V 5 (3) A 15 V 5 (3) A

Electrical connection

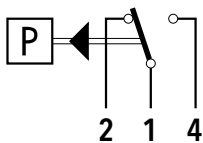

Switch 91

EX PRESSOSTAT

Swiss based Trafag is a leading international supplier of high quality sensors and monitoring instruments for measurement of pressure and temperature.



Applications

- Ex II 2 G / D

Features

- Rugged aluminium housing, option: housing stainless steel
- Protection IP66
- Any mounting position possible
- Ex db eb IIC T6 Gb
- Ex tb IIIC T80°C Db

Technical Data			
Measuring principle	Piston	Media temperature	NBR: -30°C ... +100°C FKM: -15°C ... +150°C
Measuring range	1 ... 10 to 60 ... 600 bar	Ambient temperature	-50°C ... +65°C
Output signal	1 Floating change-over contact (SPDT)	Approval / conformity	SEV 15 ATEX 0157 X IECEX SEV 17.0013X
Switching differential	Not adjustable	Type of protection	Areas with gas explosion hazards: II 2 G Ex db eb IIC T6 Gb; Areas with dust explosion hazards: II 2 D Ex tb IIIC T80°C Db
Repeatability	± 1.0 % FS typ.		

Subject to change

Ordering information/type code

		XXX	XX	XX	XXX	XX	XX			
Custom build code	With display and adjusting screw	944								
	Without display, with adjusting screw	947								
	With display and adjusting knob	953								
Microswitch	Standard, switching differential not adjustable		91							
Range	Range [bar]	Over pressure [bar]	Burst pressure [bar]							
	1 ... 10	100	200				78			
	4 ... 40	200	400				81			
	6 ... 60	200	400				82			
	10 ... 100	200	400				83			
	16 ... 160	400	600				84			
	25 ... 250	400	600				85			
	40 ... 400	800	1000				86			
60 ... 600	800	1000				87				
Sensor	Sensor material	Sensor housing material	Thread	Range	Sensor material	Sensor housing material	Thread	Range		
	Piston 1.4435, O-Ring NBR	1.4435	G1/4" female	78	700	Piston 1.4435, O-Ring FKM	1.4435	G1/4" female	82, 83	709
	Piston 1.4435, O-Ring NBR	1.4435	G1/2" male	78	702	Piston 1.4435, O-Ring FKM	1.4435	G1/2" male	82, 83	711
	Piston 1.4435, O-Ring FKM	1.4435	G1/4" female	78	701	Piston 1.4435, O-Ring NBR	1.4435	G1/4" female	84, 85	712
	Piston 1.4435, O-Ring FKM	1.4435	G1/2" male	78	703	Piston 1.4435, O-Ring NBR	1.4435	G1/2" male	84, 85	714
	Piston 1.4435, O-Ring NBR	1.4435	G1/4" female	81	704	Piston 1.4435, O-Ring FKM	1.4435	G1/4" female	84, 85	713
	Piston 1.4435, O-Ring NBR	1.4435	G1/2" male	81	706	Piston 1.4435, O-Ring FKM	1.4435	G1/2" male	84, 85	715
	Piston 1.4435, O-Ring FKM	1.4435	G1/4" female	81	705	Piston 1.4435, O-Ring NBR	1.4435	G1/4" female	86, 87	722
	Piston 1.4435, O-Ring FKM	1.4435	G1/2" male	81	707	Piston 1.4435, O-Ring NBR	1.4435	G1/2" male	86, 87	724
	Piston 1.4435, O-Ring NBR	1.4435	G1/4" female	82, 83	708	Piston 1.4435, O-Ring FKM	1.4435	G1/4" female	86, 87	723
	Piston 1.4435, O-Ring NBR	1.4435	G1/2" male	82, 83	710	Piston 1.4435, O-Ring FKM	1.4435	G1/2" male	86, 87	725
	Fixation	Direct on sensor or housing								00
		With mounting bracket								31
	Accessories	Housing stainless steel								06
		Damping elements and snubber see data sheet H72258								

Standard products (extra short lead time)

Product No.	Type Code	Pressure range [bar]	Over pressure max. [bar]	Switching differential [bar]	Diameter Y [mm]	Length X [mm]
EXPK10	944 9178 700 00 0000 0000 02	1 ... 10	100	0.4 ... 0.8 (fixed)	33	47
EXPK40	944 9181 704 00 0000 0000 02	4 ... 40	200	2 ... 5 (fixed)	27	42.5
EXPK100	944 9183 708 00 0000 0000 02	10 ... 100	200	4 ... 11 (fixed)	27	42.5
EXPK250	944 9185 712 00 0000 0000 02	25 ... 250	400	8 ... 26 (fixed)	27	42.5

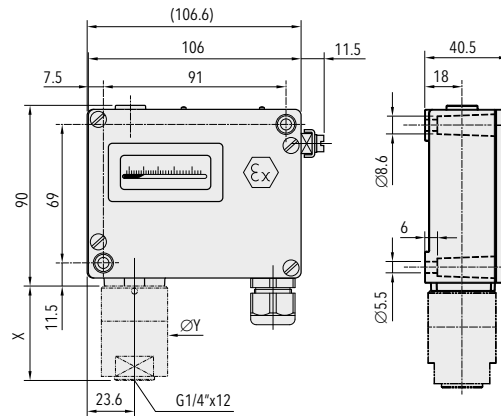

Specifications		
Accuracy	Repeatability	± 1.0 % FS typ.
	Scale accuracy typ.	± 2.0 % FS typ.
	Switching differential	See table
	Adjustment range switchpoint ¹⁾	10% ... 90% FS
Environmental conditions	Ambient temperature	-50°C ... +65°C
	Media temperature	NBR: -30°C ... +100°C FKM: -15°C ... +150°C
	Storage temperature	-50°C ... +65°C
	Protection	IP66 Accessory 06: IP66
	Humidity	Max. 95 % relative
	Vibration	5...25 Hz: ± 1.6 mm 25...100 Hz: 4g
	Shock	50g/ 11ms
Mechanical Data	Sensor	See ordering information
	Housing	AlSi10Mg/ Epoxy coated Accessory 06: 1.4301 (AISI 304)
	Sealing	NBR / FKM
	Screwed cable gland	Polyamide
	Mounting torque	Max. 25 Nm
	Installation	any position
	Weight	~ 710 g
Microswitch	Rating	See table
	Resistance of insulation	> 2 MΩ
	Dielectric strength	1.5 kV
	Life time (mechanical)	1 Mio. cycles
Electrical connection	Electrical connections	Terminal screw
	Cable gland	M20x1.5/SW24 Cable-Ø 5.5...13 mm Approval: PTB 99 ATEX 3128 X
	Terminal screw	3 x 0.5...1.5 mm ²

¹⁾ Other adjustment ranges upon request

Additional information		
Documents	Data sheet	www.trafag.com/H72270
	Instructions	www.trafag.com/H73171
	Flyer	www.trafag.com/H70917

Dimensions

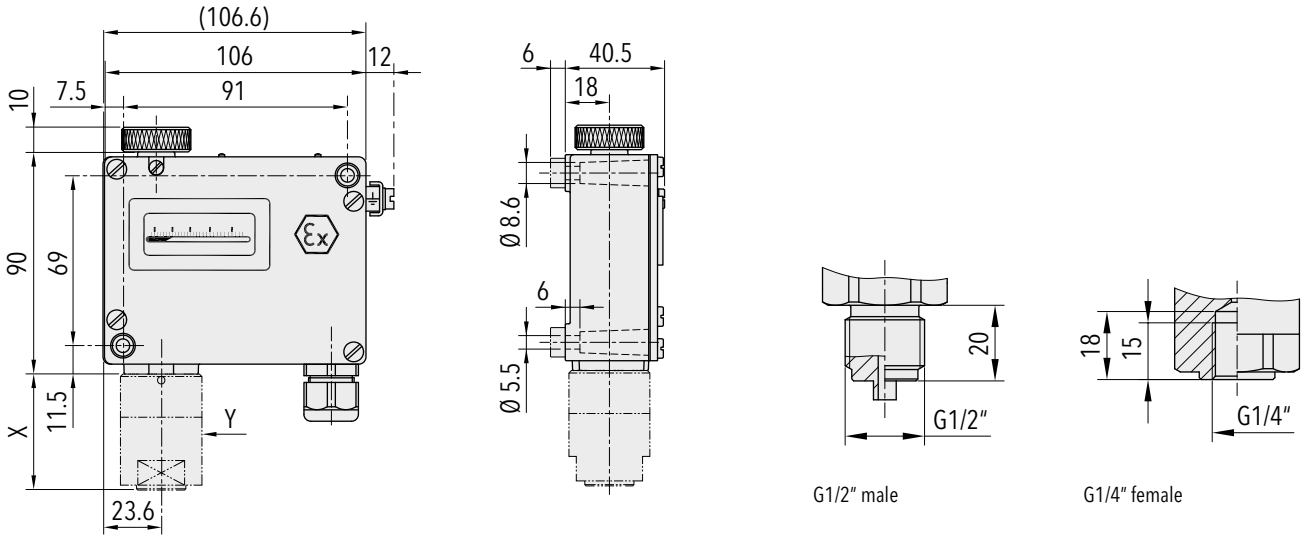

Dimension X and Y see data sheet H72271

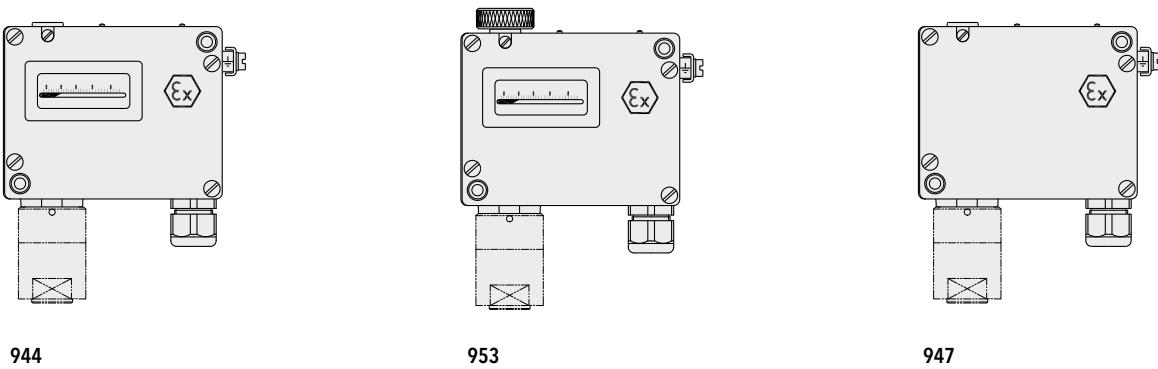

944

953

947

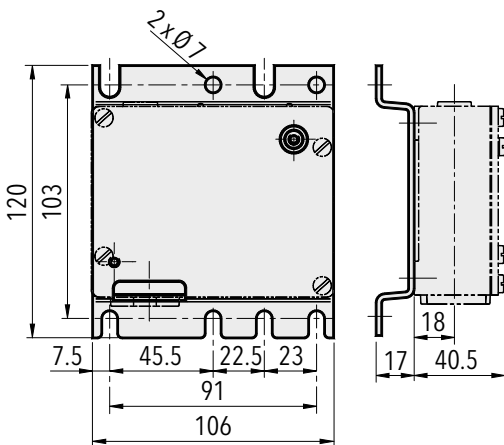

9XX.XXXX.XXX.31

Switching differential typ. @ 25°C

Measuring range of piston sensor	[bar]	1 ... 10	4 ... 40	6 ... 60	10 ... 100
Microswitch 91	[bar]	0.4 ... 0.8	2 ... 5	3 ... 8	4 ... 11
Switching differential: Variable according to set point (not adjustable)					
Measuring range of piston sensor	[bar]	16 ... 160	25 ... 250	40 ... 400	60 ... 600
Microswitch 91	[bar]	6 ... 18	8 ... 26	14 ... 42	24 ... 65
Switching differential: Variable according to set point (not adjustable)					

Electrical data switch

Type	Features	Rating	
		Resistive Load (Inductive Load)	
		AC	DC
91	Standard Ex	250V 5(5) A 125V 5(5) A	250 V 0.25 (0.03) A 125 V 0.5 (0.06) A 75 V 0.75 (0.25) A 50 V 1 (1) A 30 V 5 (3) A 15 V 5 (3) A

Electrical connection

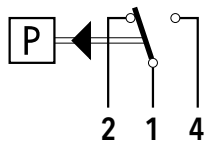

Switch 91

EX DIFFERENTIAL PRESSOSTAT

Swiss based Trafag is a leading international supplier of high quality sensors and monitoring instruments for measurement of pressure and temperature.



Applications

- Ex II 2 G / D

Features

- Rugged aluminium housing
- Protection IP66
- Ex db eb IIC T6 Gb
- Ex tb IIIC T80°C Db
- Any mounting position possible

Technical Data			
Measuring principle	Bellow	Repeatability	± 1.0 % FS typ.
Measuring range	-1 ... 6 to -1 ... 18 bar	Media temperature	-50°C ... +150°C
Differential pressure	-0.6 ... 3.4 to 1 ... 16 bar	Ambient temperature	-50°C ... +65°C
Output signal	1 Floating change-over contact (SPDT)	Approval / conformity	SEV 15 ATEX 0157 X IECEX SEV 17.0013X
Switching differential	Not adjustable	Type of protection	Areas with gas explosion hazards: II 2 G Ex db eb IIC T6 Gb; Areas with dust explosion hazards: II 2 D Ex tb IIIC T80°C Db

Subject to change

Ordering information/type code

		XXX	XX	XX	XXX	XX	XX
Custom build code	With display and adjusting screw	920					
	Without display, with adjusting screw	924					
	With display and adjusting knob	932					
Microswitch	Standard, not adjustable		91				
Range	Range [bar]	Differential pressure [bar]	Over pressure [bar]	Burst pressure [bar]			
	-1 ... 6	-0.6 ... 3.4	12	26			74
	-1 ... 6	0 ... 4	12	26			76
	-1 ... 8	0 ... 6	12	26			77
	-1 ... 12	1 ... 10	24	36			78
	-1 ... 18	1 ... 16	24	36			79
Sensor	Sensor material	Sensor housing material	Thread	Range			
	1.4435	Brass nickel plated	G1/8" female	74			881
	1.4435	Brass nickel plated	G1/8" female	76, 77			883
	1.4435	Brass nickel plated	G1/8" female	78, 79			885
	Bronze	Brass	G1/8" female	74			942
	Bronze	Brass	G1/8" female	76, 77			943
	Bronze	Brass	G1/8" female	78, 79			944
	Bronze	Brass nickel plated	G1/8" female	74			992
	Bronze	Brass nickel plated	G1/8" female	76, 77			993
	Bronze	Brass nickel plated	G1/8" female	78, 79			994
Fixing	Direct on sensor or housing						00
	With mounting bracket						31
Accessories	Adapter G1/8" male - G1/2" male, brass						A6
	Adapter G1/8" male - G1/2" male, brass nickel plated						B6
	Adapter G1/8" male - G1/2" male, stainless steel 1.4435						D6
	Adapter G1/8" male - G1/4" female, brass						A5
	Adapter G1/8" male - G1/4" female, brass nickel plated						B5
	Adapter G1/8" male - G1/4" female, stainless steel 1.4435						D5
	Damping elements and snubber see data sheet H72258						

Standard products (extra short lead time)

Product No.	Type Code	Pressure range [bar]	Differential pressure [bar]	Over pressure max. [bar]	Switching differential [bar]	Length X [mm]
EXPD3.4	920 9174 992 00 0000 0000 02	-1 ... +6	-0.6 ... +3.4	12	0.4 (fixed)	77
EXPD6	920 9177 993 00 0000 0000 02	-1 ... +8	0 ... 6	12	0.4 (fixed)	77
EXPD16	920 9179 994 00 0000 0000 02	-1 ... +18	1 ... 16	24	0.7 (fixed)	87

Specifications		
Accuracy	Repeatability	± 1.0 % FS typ.
	Scale accuracy typ.	± 2.0 % FS typ.
	Switching differential	See table
	Adjustment range switchpoint ¹⁾	10% ... 90% FS
Environmental conditions	Ambient temperature	-50°C ... +65°C
	Media temperature	-50°C ... +150°C
	Storage temperature	-50°C ... +65°C
	Protection	IP66
	Humidity	Max. 95 % relative
	Vibration	5...25 Hz: ±1.6 mm 25...100 Hz: 4g
	Shock	50g/ 11ms
Mechanical Data	Sensor	See ordering information
	Housing	AlSi10Mg/ Epoxy coated
	Sealing	NBR
	Screwed cable gland	Polyamide
	Mounting torque	Max. 25 Nm
	Installation	any position
	Weight	~ 610 g
Microswitch	Rating	See table
	Resistance of insulation	> 2 MΩ
	Dielectric strength	1.5 kV
	Life time (mechanical)	1 Mio. cycles
Electrical connection	Electrical connections	Terminal screw
	Cable gland	M20x1.5/SW24 Cable-Ø 5.5...13 mm Approval: PTB 99 ATEX 3128 X
	Terminal screw	3 x 0.5...1.5 mm ²

¹⁾ Other adjustment ranges upon request

Dimensions

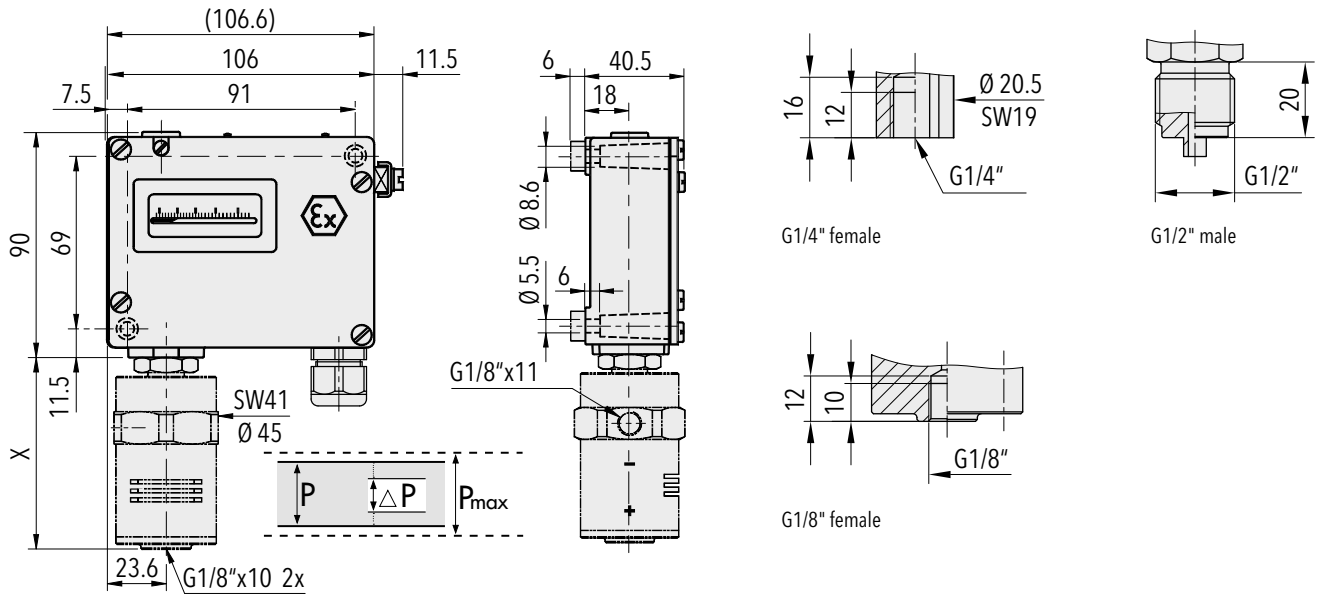

Dimension X see data sheet H72271

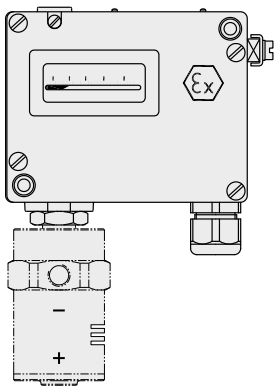

920

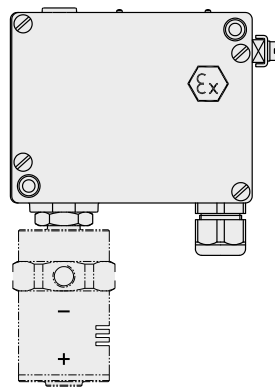

924

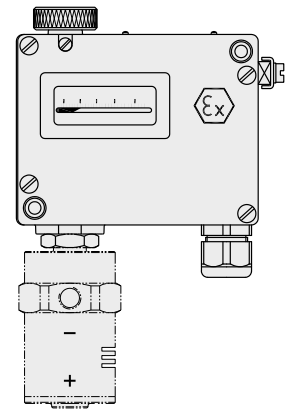

932

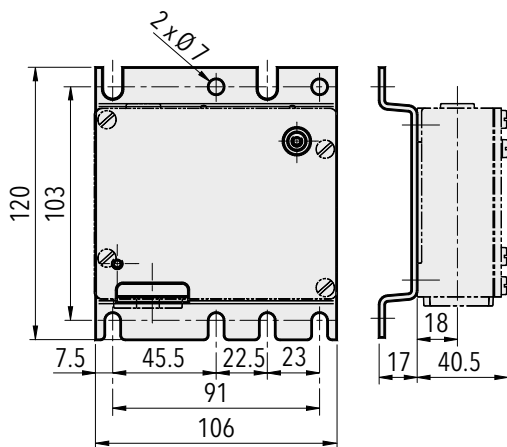

9XX.XX.XX.XXX.31.XX

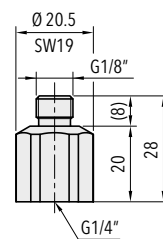

A5/B5/D5

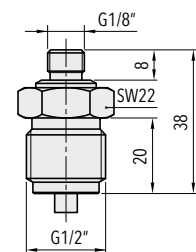

A6/B6/D6

Switching differential typ. @ 25°C

Measuring range of bellows sensor	[bar]	-0.6 ... 3.4	1 ... 10
		0 ... 4	1 ... 16
		0 ... 6	
Microswitch 91	[bar]	0.4	0.9
Switching differential (not adjustable)			

Electrical data switch

Type	Features	Rating	
		Resistive Load (Inductive Load)	
		AC	DC
91	Standard Ex	250V 5(5) A 125V 5(5) A	250 V 0.25 (0.03) A 125 V 0.5 (0.06) A 75 V 0.75 (0.25) A 50 V 1 (1) A 30 V 5 (3) A 15 V 5 (3) A

Electrical connection

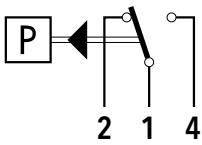

Switch 91

Additional information

Documents	Data sheet	www.trafag.com/H72256
	Instructions	www.trafag.com/H73171
	Flyer	www.trafag.com/H70922

PRESSOSTAT

Swiss based Trafag is a leading international supplier of high quality sensors and monitoring instruments for measurement of pressure and temperature.



Applications

- Potentially hazardous areas

Features

- Compact design
- Rugged housing
- Protection IP65
- Any mounting position possible
- May be used as „simple apparatus“ in zones at risk of explosions

Technical Data			
Measuring principle	Bellow	Repeatability	± 1.0 % FS typ.
Measuring range	-0.9 ... 1.5 to 10 ... 100 bar	Media temperature	-40°C ... +150°C
Output signal	1 Floating change-over contact (SPDT)	Ambient temperature	-25°C ... +70°C
Switching differential	Not adjustable	Approval / conformity	EN60730-1/ EN60730-2-6: Typ 2.B.H EN60079-0, EN60079-11 Zone 1 and 2, 21 and 22

Subject to change

«Simple Apparatus» conformity to ATEX 904

Ordering information/type code

		XXX	XX	XX	XXX	XX	XX			
Custom build code	Switch point indicator behind cover	904								
Micro-switch	With gold plated contacts, switching differential not adjustable		71							
Range	Range [bar]	Over pressure [bar]	Burst pressure [bar]		Range [bar]	Over pressure [bar]	Burst pressure [bar]			
	-0.9 ... 1.5	10	13	72	1 ... 16	24	36	79		
	0.2 ... 1.6	10	13	73	2 ... 25	40	75	80		
	0.2 ... 2.5	10	13	75	4 ... 40	40	75	81		
	0 ... 4	12	26	76	6 ... 60	100	160	82		
	0 ... 6	12	26	77	10 ... 100	100	160	83		
	1 ... 10	24	36	78						
Sensor	Sensor material	Sensor housing material	Thread	Range	Sensor material	Sensor housing material	Thread	Range		
	Bronze bellow (CuSn6)	Brass (CuZn39Pb3)	G1/4" female	72	900	Bronze bellow (CuSn6)	Brass chemically nickel plated	G1/2" male	72	959
	Bronze bellow (CuSn6)	Brass (CuZn39Pb3)	G1/4" female	73, 75	901	Bronze bellow (CuSn6)	Brass chemically nickel plated	G1/2" male	73, 75	952
	Bronze bellow (CuSn6)	Brass (CuZn39Pb3)	G1/4" female	76, 77	903	Bronze bellow (CuSn6)	Brass chemically nickel plated	G1/2" male	76, 77	954
	Bronze bellow (CuSn6)	Brass (CuZn39Pb3)	G1/4" female	78, 79	905	Bronze bellow (CuSn6)	Brass chemically nickel plated	G1/2" male	78, 79	956
	Bronze bellow (CuSn6)	Brass (CuZn39Pb3)	G1/4" female	80, 81	907	Bronze bellow (CuSn6)	Brass chemically nickel plated	G1/2" male	80, 81	958
	Stainless steel 1.4435	Brass (CuZn39Pb3)	G1/4" female	82, 83	940	Stainless steel 1.4435	Brass nickel plated	G1/4" female	72	800
	Bronze bellow (CuSn6)	Brass (CuZn39Pb3)	G1/2" male	72	909	Stainless steel 1.4435	Brass nickel plated	G1/4" female	73, 75	801
	Bronze bellow (CuSn6)	Brass (CuZn39Pb3)	G1/2" male	73, 75	902	Stainless steel 1.4435	Brass nickel plated	G1/4" female	76, 77	803
	Bronze bellow (CuSn6)	Brass (CuZn39Pb3)	G1/2" male	76, 77	904	Stainless steel 1.4435	Brass nickel plated	G1/4" female	78, 79	805
	Bronze bellow (CuSn6)	Brass (CuZn39Pb3)	G1/2" male	78, 79	906	Stainless steel 1.4435	Brass nickel plated	G1/4" female	80, 81	807
	Bronze bellow (CuSn6)	Brass (CuZn39Pb3)	G1/2" male	80, 81	908	Stainless steel 1.4435	Brass nickel plated	G1/4" female	82, 83	840
	Stainless steel 1.4435	Brass (CuZn39Pb3)	G1/2" male	82, 83	941	Stainless steel 1.4435	Brass nickel plated	G1/2" male	72	809
	Bronze bellow (CuSn6)	Brass chemically nickel plated	G1/4" female	72	950	Stainless steel 1.4435	Brass nickel plated	G1/2" male	73, 75	802
	Bronze bellow (CuSn6)	Brass chemically nickel plated	G1/4" female	73, 75	951	Stainless steel 1.4435	Brass nickel plated	G1/2" male	76, 77	804
	Bronze bellow (CuSn6)	Brass chemically nickel plated	G1/4" female	76, 77	953	Stainless steel 1.4435	Brass nickel plated	G1/2" male	78, 79	806
	Bronze bellow (CuSn6)	Brass chemically nickel plated	G1/4" female	78, 79	955	Stainless steel 1.4435	Brass nickel plated	G1/2" male	80, 81	808
	Bronze bellow (CuSn6)	Brass chemically nickel plated	G1/4" female	80, 81	957	Stainless steel 1.4435	Brass nickel plated	G1/2" male	82, 83	841
Fixation	Direct on sensor or housing							00		
	With mounting bracket							31		
Accessories	Sealing switchpoint (manipulation protection)							16		
	Damping elements and snubber see data sheet H72258									

Optional accessories of third party supplier

Ex-i barriers are suitable for intrinsically safe applications. The device transmits binary signals from the hazardous area into the safe area.

Ex-i-barriers: 24 VDC $U_0 = 10.5 \text{ V} / I_0 = 13 \text{ mA} / P_0 = 34 \text{ mW} =$	ZEN24VDC
Ex-i-barriers: 230 VAC $U_0 = 10.6 \text{ V} / I_0 = 19.1 \text{ mA} / P_0 = 51 \text{ mW} =$	ZEN230VAC

i Pressostats, when combined with a certified Ex-barrier (see "optional accessories of third party supplier"), can be used as "simple electrical apparatus" in Zone 1 and 2, as well as in Zone 21 and 22, according to IEC/EN 60079-14. These pressostats are not suitable for Zone 0 and Zone 20. Use in safety relevant applications (approved electrical apparatus) is not permitted.

«Simple Apparatus» conformity to ATEX 904

Specifications		
Accuracy	Repeatability	± 1.0 % FS typ.
	Scale accuracy typ.	± 2.0 % FS typ.
	Switching differential	See table
	Adjustment range switchpoint ¹⁾	10 % ... 90 % FS
Environmental conditions	Ambient temperature	-25°C ... +70°C
	Media temperature	-40°C ... +150°C
	Storage temperature	-25°C ... +85°C
	Protection	IP65
	Humidity	Max.95 % relative
	Vibration	5...25 Hz: ±1.6 mm 25...100 Hz: 4 g Ranges 72, 73, 75 5...50 Hz: 20 mm/sec.
	Shock	50 g / 11 ms
Mechanical Data	Sensor	See ordering information
	Housing	AlSi10Mg/ Epoxy coated
	Sealing	NBR
	Screwed cable gland	Polyamide (PA), light blue
	Mounting torque	Max. 25 Nm
	Installation	any position
	Weight	~ 710 g
Microswitch	Rating	See table
	Resistance of insulation	> 2 MΩ
	Dielectric strength	1.25 kV terminal ground
	Life time (mechanical)	1 Mio. cycles
Electrical connection	Cable gland	M20x1.5 Cable-Ø 4...10 mm, max. cable length according to EN 60079-11
	Terminal screw	3 x 1.5...4 mm ²

¹⁾ Other adjustment ranges upon request

«Simple Apparatus» conformity to ATEX 904

Switching differential typ. @ 25°C						
Measuring range bellows sensor	[bar]	-0.9 ... 1.5	0 ... 4	1 ... 10	2 ... 25	6 ... 60
		0.2 ... 1.6	0 ... 6	1 ... 16	4 ... 40	10 ... 100
		0.2 ... 2.5				
Microswitch 71: Switching differential not adjustable	[bar]	0.1	0.2	0.4	1.0	3.0

Electrical data switch		
Type	Features	Rating
71	Gold plated contacts	$U_0 = 24\text{ V}$ $I_0 = 100\text{ mA}$ $P_0 = 600\text{ mW}$

Electrical connection

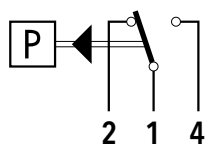

904

Additional information		
Documents	Data sheet	www.trafag.com/H72364
	Instructions	www.trafag.com/H73175
	Flyer	www.trafag.com/H70919

DIFFERENTIAL PRESSURE PRESSOSTAT

Swiss based Trafag is a leading international supplier of high quality sensors and monitoring instruments for measurement of pressure and temperature.



Applications

- Potentially hazardous areas

Features

- Compact design
- Rugged housing
- Protection IP65
- Any mounting position possible
- May be used as „simple apparatus“ in zones at risk of explosions

Technical Data			
Measuring principle	Bellow	Repeatability	± 1.0 % FS typ.
Measuring range	-1 ... 6 to -1 ... 18 bar	Media temperature	-40°C ... +150°C
Differential pressure	-0.6 ... 3.4 to 1 ... 16 bar	Ambient temperature	-25°C ... +70°C
Output signal	1 Floating change-over contact (SPDT)	Approval / conformity	EN60730-1/ EN60730-2-6: Typ 2.B.H EN60079-0, EN60079-11 Zone 1 and 2, 21 and 22
Switching differential	Not adjustable		

Subject to change

«Simple Apparatus» conformity to ATEX 924

Ordering information/type code

		XXX	XX	XX	XXX	XX	XX	
Custom build code	Switch point indicator behind cover	924						
Microswitch	With gold plated contacts, switching differential not adjustable		71					
Range	Range [bar]	Differential pressure [bar]	Over pressure [bar]	Burst pressure [bar]				
	-1 ... 6	-0.6 ... 3.4	12	26			74	
	-1 ... 6	0 ... 4	12	26			76	
	-1 ... 8	0 ... 6	12	26			77	
	-1 ... 12	1 ... 10	24	36			78	
	-1 ... 18	1 ... 16	24	36			79	
Sensor	Sensor material	Sensor housing material	Thread	Range	Sensor material	Sensor housing material	Thread	Range
	Bronze	Brass	G1/8" female	74	Bronze	Brass chemically nickel plated	G1/4" female	78, 79
				931				988
	Bronze	Brass	G1/8" female	76, 77	Bronze	Brass chemically nickel plated	G1/2" male	74
				933				982
	Bronze	Brass	G1/8" female	78, 79	Bronze	Brass chemically nickel plated	G1/2" male	76, 77
				935				984
	Bronze	Brass	G1/4" female	74	Bronze	Brass chemically nickel plated	G1/2" male	78, 79
				930				986
	Bronze	Brass	G1/4" female	76, 77	Stainless steel 1.4435	Brass nickel plated	G1/8" female	74
				937				831
	Bronze	Brass	G1/4" female	78, 79	Stainless steel 1.4435	Brass nickel plated	G1/8" female	76, 77
				938				833
	Bronze	Brass	G1/2" male	74	Stainless steel 1.4435	Brass nickel plated	G1/8" female	78, 79
				932				835
	Bronze	Brass	G1/2" male	76, 77	Stainless steel 1.4435	Brass nickel plated	G1/4" female	74
				934				830
	Bronze	Brass	G1/2" male	78, 79	Stainless steel 1.4435	Brass nickel plated	G1/4" female	76, 77
				936				837
	Bronze	Brass chemically nickel plated	G1/8" female	74	Stainless steel 1.4435	Brass nickel plated	G1/4" female	78, 79
				981				838
	Bronze	Brass chemically nickel plated	G1/8" female	76, 77	Stainless steel 1.4435	Brass nickel plated	G1/2" male	74
				983				832
	Bronze	Brass chemically nickel plated	G1/8" female	78, 79	Stainless steel 1.4435	Brass nickel plated	G1/2" male	76, 77
				985				834
	Bronze	Brass chemically nickel plated	G1/4" female	74	Stainless steel 1.4435	Brass nickel plated	G1/2" male	78, 79
				980				836
	Bronze	Brass chemically nickel plated	G1/4" female	76, 77				987
Fixation	Direct on sensor or housing							00
	With mounting bracket							31
Accessories	Lead seal (manipulation protection)							16
	Adapter G1/8" male - G1/2" male, brass							A6
	Adapter G1/8" male - G1/2" male, brass nickel plated							B6
	Adapter G1/8" male - G1/2" male, stainless steel 1.4435							D6
	Adapter G1/8" male - G1/4" female, brass							A5
	Adapter G1/8" male - G1/4" female, brass nickel plated							B5
	Adapter G1/8" male - G1/4" female, stainless steel 1.4435							D5
	Damping elements and snubber see data sheet H72258							

Optional accessories of third party supplier

Ex-i barriers are suitable for intrinsically safe applications. The device transmits binary signals from the hazardous area into the safe area.

Ex-i barriers: 24 VDC $U_0 = 10.5 \text{ V}$ / $I_0 = 13 \text{ mA}$ / $P_0 = 34 \text{ mW} =$ **ZEN24VDC**

Ex-i barriers: 230 VAC $U_0 = 10.6 \text{ V}$ / $I_0 = 19.1 \text{ mA}$ / $P_0 = 51 \text{ mW} =$ **ZEN230VAC**

i Pressostats, when combined with a certified Ex-barrier (see "optional accessories of third party supplier"), can be used as "simple electrical apparatus" in Zone 1 and 2, as well as in Zone 21 and 22, according to IEC/EN 60079-14. These pressostats are not suitable for Zone 0 and Zone 20. Use in safety relevant applications (approved electrical apparatus) is not permitted.

«Simple Apparatus» conformity to ATEX 924

Specifications		
Accuracy	Repeatability	± 1.0 % FS typ.
	Scale accuracy typ.	± 2.0 % FS typ.
	Switching differential	See table
	Adjustment range switchpoint ¹⁾	10 % ... 90 % FS
Environmental conditions	Ambient temperature	-25°C ... +70°C
	Media temperature	-40°C ... +150°C
	Storage temperature	-25°C ... +85°C
	Protection	IP65
	Humidity	Max. 95 % relative
	Vibration	5...25 Hz: ±1.6 mm 25...100 Hz: 4 g
	Shock	50 g / 11 ms
Mechanical Data	Sensor	See ordering information
	Housing	AlSi10Mg/ Epoxy coated
	Sealing	NBR
	Screwed cable gland	Polyamide (PA), light blue
	Mounting torque	Max. 25 Nm
	Installation	any position
	Weight	~ 610 g
Microswitch	Rating	See table
	Resistance of insulation	> 2 MΩ
	Dielectric strength	1.25 kV terminal ground
	Life time (mechanical)	1 Mio. cycles
Electrical connection	Cable gland	M20x1.5 Cable-Ø 4...10 mm, max. cable length according to EN 60079-11
	Terminal screw	3 x 1.5...4 mm ²

¹⁾ Other adjustment ranges upon request

«Simple Apparatus» conformity to ATEX 924

Dimensions

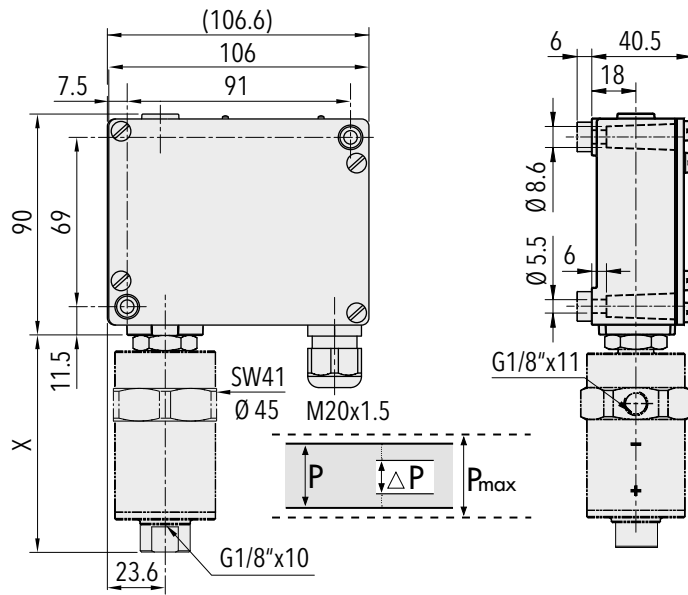

924.71.XX.XXX.XX.XX

Dimension X see data sheet H72271

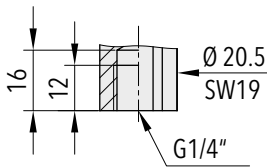

G1/4" female

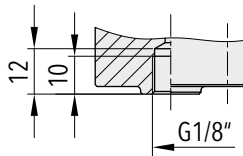

G1/8" female

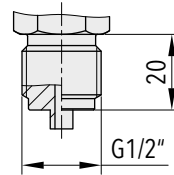

G1/2" male

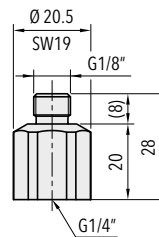
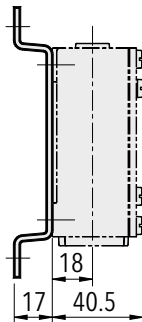
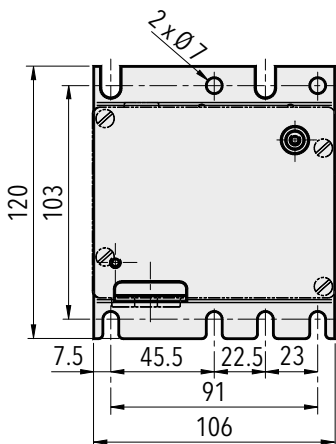

A5/B5/D5

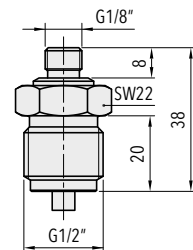

A6/B6/D6

924.XX.XX.XXX.31.XX

«Simple Apparatus» conformity to ATEX 924

Switching differential typ. @ 25°C

Measuring range bellows sensor	[bar]	-1 ... 6 -1 ... 8	-1 ... 12 -1 ... 18
Microswitch 71: Switching differential not adjustable	[bar]	0.16	0.4

Electrical data switch

Type	Features	Rating
71	Gold plated contacts	$U_0 = 24\text{ V}$ $I_0 = 100\text{ mA}$ $P_0 = 600\text{ mW}$

Electrical connection

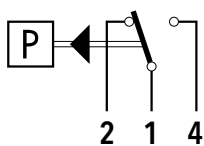

924

Additional information

Documents	Data sheet	www.trafag.com/H72365
	Instructions	www.trafag.com/H73175
	Flyer	www.trafag.com/H70920

PRESSOSTAT

Swiss based Trafag is a leading international supplier of high quality sensors and monitoring instruments for measurement of pressure and temperature.



Applications

- Potentially hazardous areas

Features

- Compact design
- Rugged housing
- Protection IP65
- Any mounting position possible
- May be used as „simple apparatus“ in zones at risk of explosions

Technical Data			
Measuring principle	Piston	Repeatability	± 1.0 % FS typ.
Measuring range	1 ... 10 to 60 ... 600 bar	Media temperature	O-Ring NBR: -30°C ... +100°C O-Ring FKM: -15°C ... +150°C
Output signal	1 Floating change-over contact (SPDT)	Ambient temperature	-25°C ... 70°C
Switching differential	Not adjustable	Approval / conformity	EN60730-1/ EN60730-2-6: Typ 2.B.H EN60079-0, EN60079-11 Zone 1 and 2, 21 and 22

Subject to change

«Simple Apparatus» conformity to ATEX 947

Ordering information/type code

		XXX	XX	XX	XXX	XX	XX			
Custom build code	Switch point indicator behind cover	947								
Microswitch	With gold plated contacts, switching differential not adjustable		71							
Range	Range [bar]	Over pressure [bar]	Burst pressure [bar]							
	1 ... 10	100	200			78				
	4 ... 40	200	400			81				
	6 ... 60	200	400			82				
	10 ... 100	200	400			83				
	16 ... 160	400	600			84				
	25 ... 250	400	600			85				
	40 ... 400	800	1000			86				
	60 ... 600	800	1000			87				
Sensor	Sensor material	Sensor housing material	Thread	Range	Sensor material	Sensor housing material	Thread	Range		
	Stainless steel 1.4435 ²⁾	Stainless steel 1.4435	G1/4" female	78	700	Stainless steel 1.4435 ³⁾	Stainless steel 1.4435	G1/4" female	78	701
	Stainless steel 1.4435 ²⁾	Stainless steel 1.4435	G1/4" female	81	704	Stainless steel 1.4435 ³⁾	Stainless steel 1.4435	G1/4" female	81	705
	Stainless steel 1.4435 ²⁾	Stainless steel 1.4435	G1/4" female	82, 83	708	Stainless steel 1.4435 ³⁾	Stainless steel 1.4435	G1/4" female	82, 83	709
	Stainless steel 1.4435 ²⁾	Stainless steel 1.4435	G1/4" female	84, 85	712	Stainless steel 1.4435 ³⁾	Stainless steel 1.4435	G1/4" female	84, 85	713
	Stainless steel 1.4435 ²⁾	Stainless steel 1.4435	G1/4" female	86, 87	722	Stainless steel 1.4435 ³⁾	Stainless steel 1.4435	G1/4" female	86, 87	723
	Stainless steel 1.4435 ²⁾	Stainless steel 1.4435	G1/2" male	78	702	Stainless steel 1.4435 ³⁾	Stainless steel 1.4435	G1/2" male	78	703
	Stainless steel 1.4435 ²⁾	Stainless steel 1.4435	G1/2" male	81	706	Stainless steel 1.4435 ³⁾	Stainless steel 1.4435	G1/2" male	81	707
	Stainless steel 1.4435 ²⁾	Stainless steel 1.4435	G1/2" male	82, 83	710	Stainless steel 1.4435 ³⁾	Stainless steel 1.4435	G1/2" male	82, 83	711
	Stainless steel 1.4435 ²⁾	Stainless steel 1.4435	G1/2" male	84, 85	714	Stainless steel 1.4435 ³⁾	Stainless steel 1.4435	G1/2" male	84, 85	715
	Stainless steel 1.4435 ²⁾	Stainless steel 1.4435	G1/2" male	86, 87	724	Stainless steel 1.4435 ³⁾	Stainless steel 1.4435	G1/2" male	86, 87	725
Fixing	Direct on sensor or housing									00
	With mounting bracket									31
Accessories	Sealing switchpoint (manipulation protection)									16
	Damping elements and snubber see data sheet H72258									

²⁾ Seal NBR

³⁾ Seal FKM

Optional accessories of third party supplier

Ex-i barriers are suitable for intrinsically safe applications. The device transmits binary signals from the hazardous area into the safe area.

Ex-i-barriers: 24 VDC $U_0 = 10.5 \text{ V} / I_0 = 13 \text{ mA} / P_0 = 34 \text{ mW} =$	ZEN24VDC
Ex-i-barriers: 230 VAC $U_0 = 10.6 \text{ V} / I_0 = 19.1 \text{ mA} / P_0 = 51 \text{ mW} =$	ZEN230VAC



Pressostats, when combined with a certified Ex-barrier (see "optional accessories of third party supplier"), can be used as "simple electrical apparatus" in Zone 1 and 2, as well as in Zone 21 and 22, according to IEC/EN 60079-14. These pressostats are not suitable for Zone 0 and Zone 20. Use in safety relevant applications (approved electrical apparatus) is not permitted.

«Simple Apparatus» conformity to ATEX 947

Specifications		
Accuracy	Repeatability	± 1.0 % FS typ.
	Scale accuracy typ.	± 2.0 % FS typ.
	Switching differential	See table
	Adjustment range switchpoint ¹⁾	10 % ... 90 % FS
Environmental conditions	Ambient temperature	-25°C ... 70°C
	Media temperature	O-Ring NBR: -30°C ... +100°C O-Ring FKM: -15°C ... +150°C
	Storage temperature	-25°C ... 85°C
	Protection	IP65
	Humidity	Max. 95 % relative
	Vibration	5...25 Hz: ±1.6 mm 25...100 Hz: 4 g
	Shock	50 g / 11 ms
	Mechanical Data	Sensor
Housing		AlSi10Mg/ Epoxy coated
Sealing		NBR
Screwed cable gland		Polyamide (PA), light blue
Mounting torque		Max. 25 Nm
Installation		any position
Weight		~ 710 g
Microswitch		Rating
	Resistance of insulation	> 2 MΩ
	Dielectric strength	1.25 kV terminal ground
	Life time (mechanical)	1 Mio. cycles
Electrical connection	Cable gland	M20x1.5 Cable-Ø 4...10 mm, max. cable length according to EN 60079-11
	Terminal screw	3 x 1.5...4 mm ²

¹⁾ Other adjustment ranges upon request

«Simple Apparatus» conformity to ATEX 947

Switching differential typ. @ 25°C									
Measuring range of piston sensor	[bar]	1 ... 10	4 ... 40	6 ... 60	10 ... 100	16 ... 160	25 ... 250	40 ... 400	60 ... 600
Microswitch 71	[bar]	0.45 ...	1.8 ... 3.4	2.3 ... 4.8	3.2 ... 7.5	4.1 ... 11	5.2 ... 16	6.5 ... 23	8 ... 32
Switching differential (not adjustable)		0.9							

Electrical data switch		
Type	Features	Rating
71	Gold plated contacts	$U_0 = 24 \text{ V}$ $I_0 = 100 \text{ mA}$ $P_0 = 600 \text{ mW}$

Electrical connection

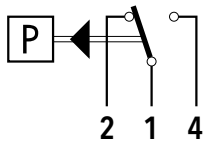

947

Additional information		
Documents	Data sheet	www.trafag.com/H72366
	Instructions	www.trafag.com/H73175
	Flyer	www.trafag.com/H70921

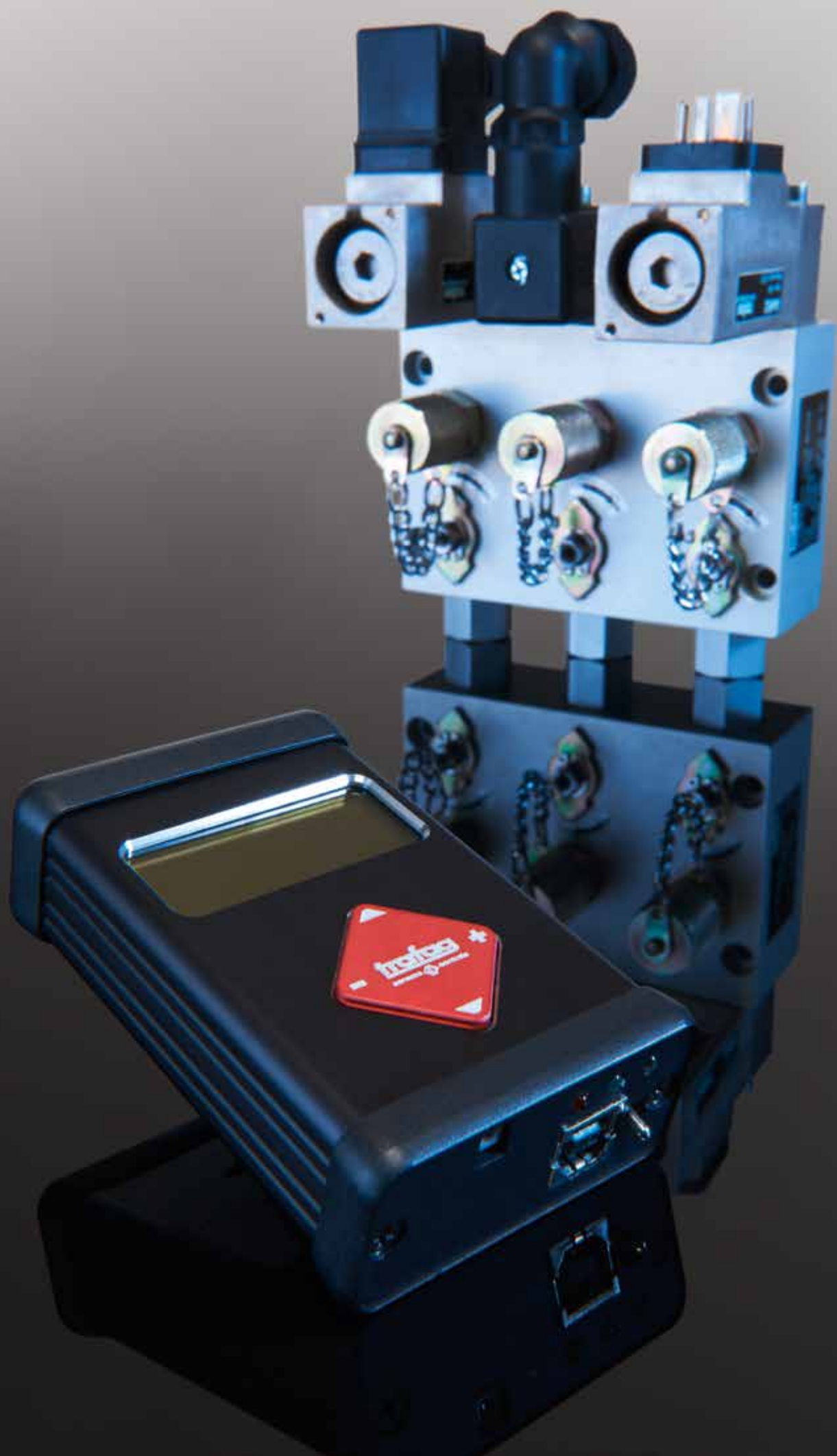

Accessories

Trafag offers a wide range of original accessories which are ideally matched to our products. These include devices for monitoring or configuring transmitters such as hand pumps with precision pressure gauge or the Sensor Communicator, a handheld device which provides direct access to the calibration values of the transmitter in the Trafag ASIC. Trafag also offers a wide range of accessories meet specific application requirements and also make installation easier. They include diagnostic valve manifolds, snubbers and pressure peak damping elements for measuring pressure, or protective pipes for thermostats.

Accessories for pressure measurement instruments

- SMI Sensor Master Interface
- SC Sensor Communicator
- CAN2USB CANopen Configuration Tool
- DVB Diagnostic Valve Block
- Hand pump with precision manometer
- Switch amplifier
- Venting box
- Cable hanger
- Pressure peak damping element
- Snubber
- Adapters for different pressure connections
- Stop valve

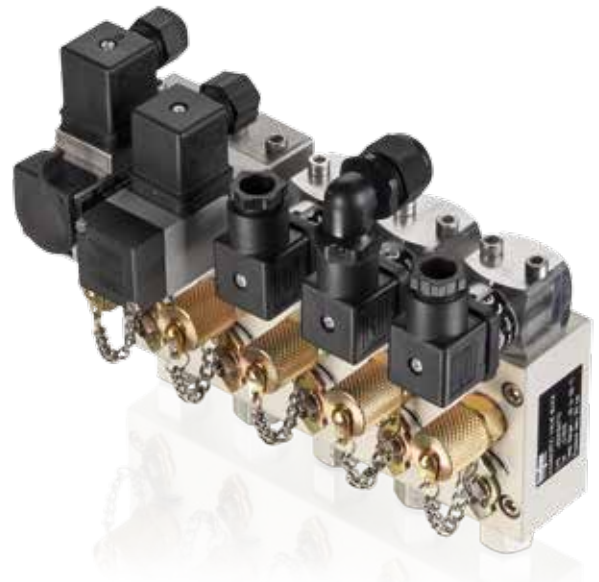

DVB

Diagnostic Valve Block

Features

- Function tests during operation (no interruption necessary) with stop valve and test connection



Technical Data

Pressure	-0.8 ... 100 bar
Ambient temperature	-20°C ... +120°C



Data sheet
Instruction

www.trafag.com/H72361
www.trafag.com/H73361

Standard products (extra short lead time)

Product No		Material	Product No		Material
DVB11	1 P-in, 1 test connection, 1 P-out	Al, PEEK, FPM	DVB24	1 P-in, 4 test connection, 4 P-out	Al, PEEK, FPM
DVB12	2 P-in, 2 test connection, 2 P-out	Al, PEEK, FPM	DVB25	1 P-in, 5 test connection, 5 P-out	Al, PEEK, FPM
DVB13	3 P-in, 3 test connection, 3 P-out	Al, PEEK, FPM	DVB32	1 P-in, 1 test connection, 2 P-out	Al, PEEK, FPM
DVB14	4 P-in, 4 test connection, 4 P-out	Al, PEEK, FPM	DVB33	1 P-in, 1 test connection, 3 P-out	Al, PEEK, FPM
DVB15	5 P-in, 5 test connection, 5 P-out	Al, PEEK, FPM	DVB34	1 P-in, 1 test connection, 4 P-out	Al, PEEK, FPM
DVB22	1 P-in, 2 test connection, 2 P-out	Al, PEEK, FPM	DVB35	1 P-in, 1 test connection, 5 P-out	Al, PEEK, FPM
DVB23	1 P-in, 3 test connection, 3 P-out	Al, PEEK, FPM			

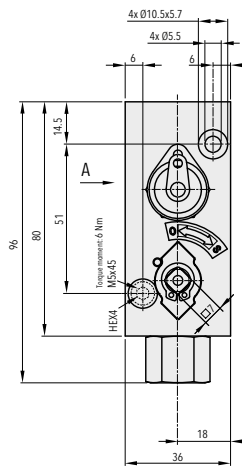
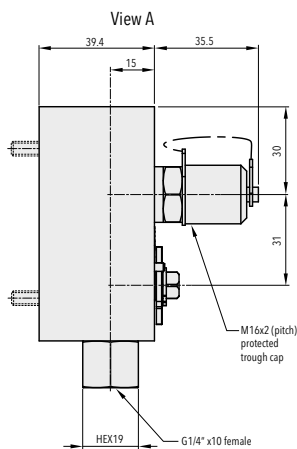
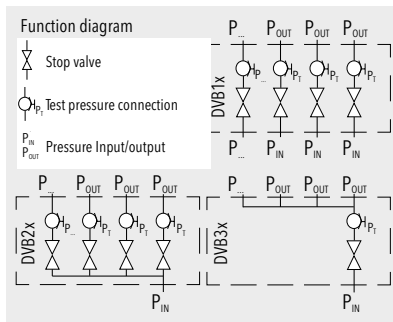

DVB11

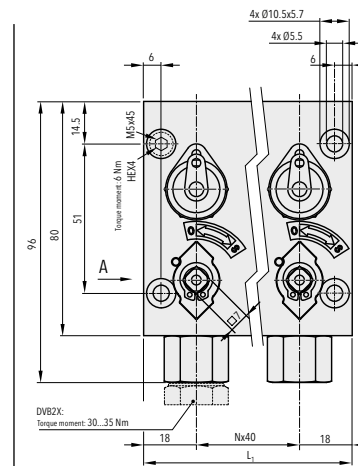

DVB X2... X5

THP...

Hand pump

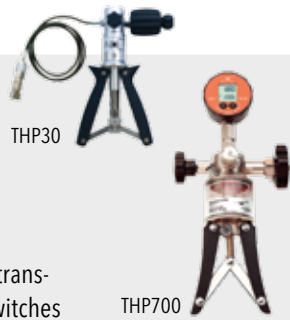

Features

- For testing of pressure transmitters and pressure switches

Technical Data

Connection G1/4" female

Standard products (extra short lead time)

Product No	Range [bar]	
THP30	-0.85 ... +25	
THP700	0 ... 700	Resolution 0.2 bar

ZEN...

Switch amplifier

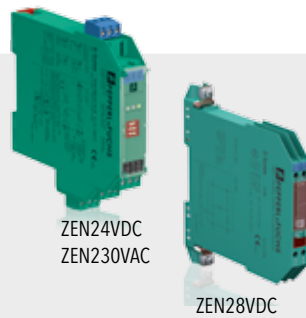

Features

- Ex II 1 G Ex ia IIC Ga
- Ex II 1 D Ex ia IIIC Da
- Ex I M1 Ex ia I Ma
- IP 20
- Output: Signal, relays

Technical Data

Ambient temperature -20°C ... +60°C

The switch amplifier transfers digital signals from the hazardous area. Sensors per DIN EN 60947-5-6 (NAMUR) and mechanical contacts may be used as alarms. The control circuit is monitored for lead breakage (LB).

Standard products (extra short lead time)

Product No	Connection	
ZEN24VDC	20 ... 30 VDC, 20 ... 23 mA	$U_0 = 10.5 \text{ V}, I_0 = 13 \text{ mA}, P_0 = 34 \text{ mW}$
ZEN230VAC	207 ... 253 VAC, 45 ... 65 Hz	$U_0 = 10.6 \text{ V}, I_0 = 19.1 \text{ mA}, P_0 = 51 \text{ mW}$
ZEN28VDC	Max. 28 VDC	$U_0 = 28 \text{ V}, I_0 = 93 \text{ mA}, P_0 = 650 \text{ mW}$

A../D..

Adapters with manometer pressure ports

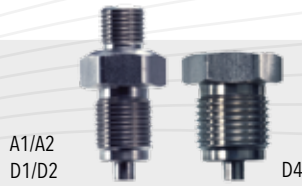

Features

- Pressure adapters with different thread combinations and materials for individual applications

Technical Data

Material	1.4435 (AISI316L) / Brass
Connection	G1/4"m - G1/2"m, G1/4"m - G3/8"m, G1/4"f - G1/2"m



Data sheet

www.trafag.com/H72258

Standard products (extra short lead time)

Product No		Material
A1	G1/4" male - G3/8" male manometer	Brass
A2	G1/4" male - G1/2" male manometer	Brass
D1	G1/4" male - G3/8" male manometer	1.4435 (AISI316L)
D2	G1/4" male - G1/2" male manometer	1.4435 (AISI316L)
D4	G1/4" female - G1/2" male manometer	1.4435 (AISI316L)

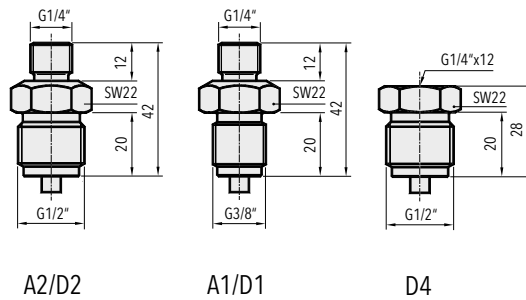

K.../F...

Snubber



Features

- Integrated in an adapter
- K1/K2: Pressure peak damping element integrated in an adapter

Technical Data

Material	1.4435/316L, brass
Connection	G1/4" male - female, G1/8" male - female



Data sheet

www.trafag.com/H72258

Standard products (extra short lead time)

Product No		Connection	Material
F3	Snubber for heavy oil	G1/4" male - female	Brass
F4	Snubber for light oil	G1/4" male - female	Brass
F5	Snubber for water/air	G1/4" male - female	Brass
K1	Snubber for water/air/light oil	G1/4" male - female	1.4435 (AISI316L)
K2	Snubber for water/air/light oil	G1/8" male - female	1.4435 (AISI316L)
K3	Snubber for heavy oil	G1/4" male - female	1.4435 (AISI316L)
K4	Snubber for light oil	G1/4" male - female	1.4435 (AISI316L)
K5	Snubber for water/air	G1/4" male - female	1.4435 (AISI316L)

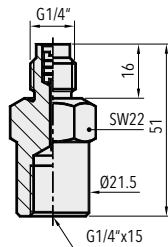

K3/K4/K5
F3/F4/F5

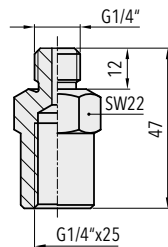

K1

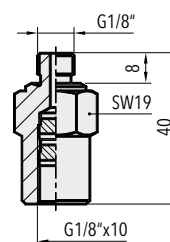

K2

MB31

Mounting Plate



Features

- For pressure transmitters and pressure switches

Technical Data

Material	Steel galvanised
----------	------------------

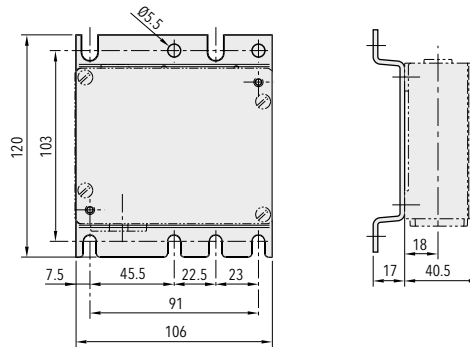

Standard products (extra short lead time)

Product No	Suitable for type	Material
MB31	N, ND, P, PS, PV, PD, PK, PVF, EXP, EXPK, EXPD	Steel galvanised

CG

Screwed cable gland



Features

- DIN 8280 for shipbuilding
- Retrofit for pressure transmitters, pressure switches and thermostats

Technical Data

Material	Brass
Connection	M18x1.5, M24x1.5
Cable	Ø 10.5 mm, 16.5 mm

Standard products (extra short lead time)

Product No		Material
CG18	M18x1.5 for 8 ... 10.5 mm cable diameter	Brass
CG24	M24x1.5 for 14 ... 16.5 mm cable diameter	Brass

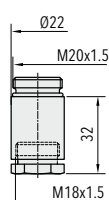

CG18

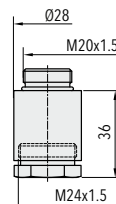

CG24

Terminology for pressure measurement instruments

Relevant standards

DIN 16086, IEC 61298-2

Instrument types

Pressure sensors

Membranes with elements applied whose physical properties change when the membranes deform (strain gauges with changing resistance, for example).

Pressure transmitters

Transmitters for converting the pressure to be measured into a defined or standardised analogue and/or digital output signal.

Pressure transducers

Pressure sensors that have a process connection and electrical connection (e.g. connector) but do not convert pressure into a standardised electrical signal like a pressure transmitter.

Types of pressure measurement

Differential pressure measurement

The measurement of differential pressure of two different pressures. The measuring instrument has two pressure connections.

Absolute pressure measurement

The measuring result is always the deviation to the absolute zero (vacuum).

e.g. 4 mA = 0 bar (= vacuum); zero point (ZP): 0 bar

Relative pressure measurement DIN 16086: overpressure

The measuring result is always the deviation to the current, absolute atmospheric pressure.

e.g. 4 mA = 960 mbar (= atmospheric pressure); zero point (ZP): 0 bar

Relative pressure measurement

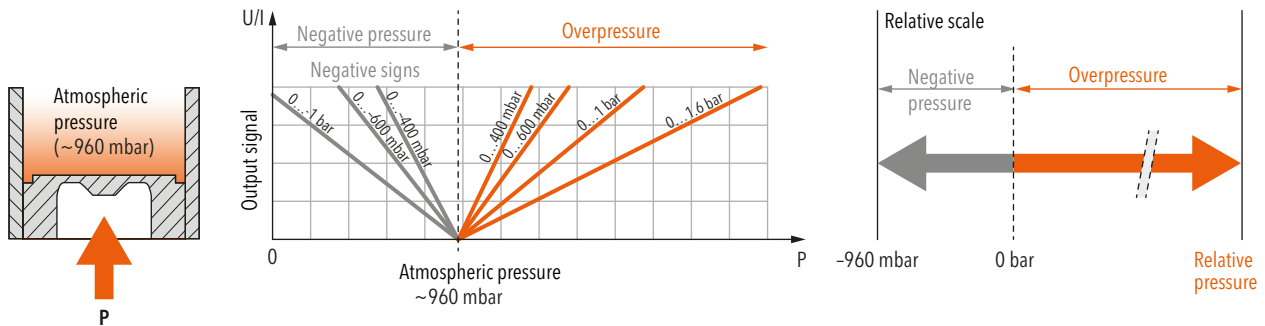

Absolute pressure measurement

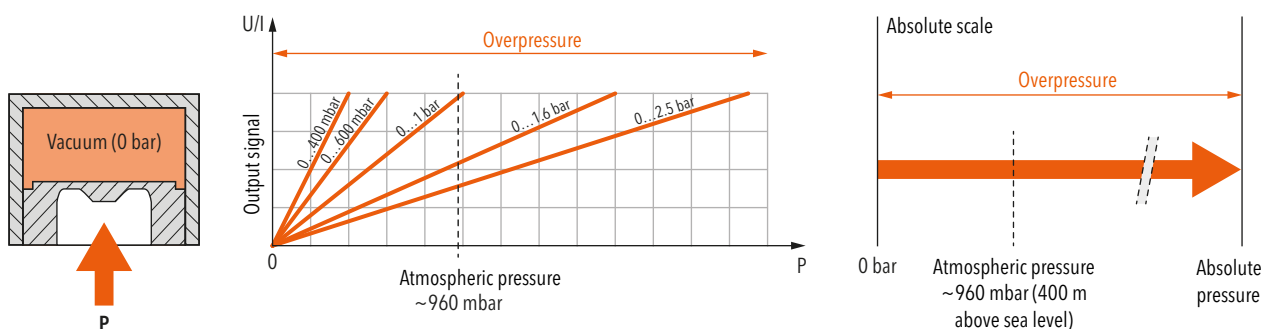

Terminology for pressure measurement instruments

Main features

Nominal pressure measuring range

Range between the upper and lower limits of the size measured (operating pressure). The specified accuracy remains within this range.

Measuring span

Algebraic difference between the upper and lower limit values of a certain measuring range.

Overpressure Max. working pressure

Highest pressure specified by manufacturer for which the pressure transformer is designed at maximum temperature. The pressure transformer can be loaded up to this pressure without the guaranteed metrological properties having changed after going back into the measuring range. However, there is no longer a clear link between pressure and output signal in the range between nominal pressure and overpressure.

Burst pressure

Pressure value (static) at which the measuring instrument suffers permanent damage. The instrument can withstand pressures up to this value without bursting and will not leak any measuring medium.

Example

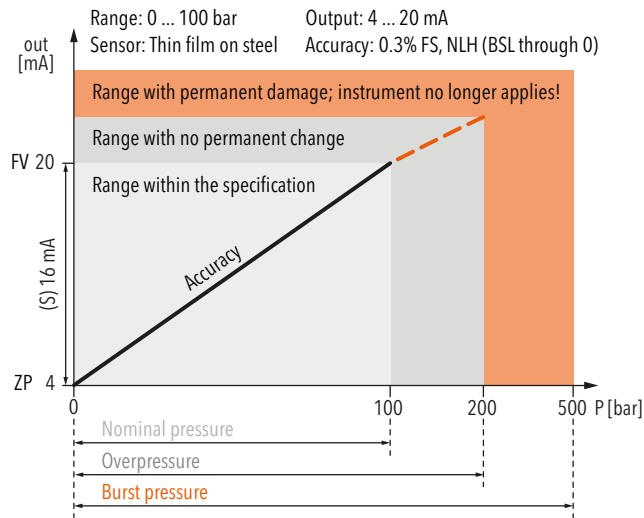

Accuracy

Typ. accuracy

(Typical) Mostly corresponds to the 1-sigma value of the normal distribution, i.e. approx. 68.3%. Generally, well over 75% of all Trafag instruments meet this typical measured value.

Max. accuracy

(maximum) 100 % of all instruments meet this maximum measured value.

Non-linearity

The largest deviation from the effective characteristic line of an ideal reference line. The reference line can be defined as a limit point adjustment, a BSL or a BSL through 0.

Specifications: Non-linearity, Hysteresis

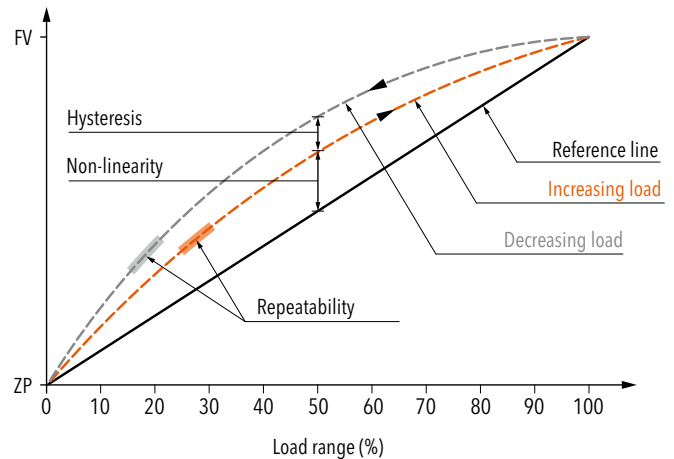

BSL Best Straight Line

The reference line according to the BSL or the minimum value adjustment is placed in such a way that the maximum positive and negative deviations are as small as possible.

Specifications: Accuracy NLH (BSL)

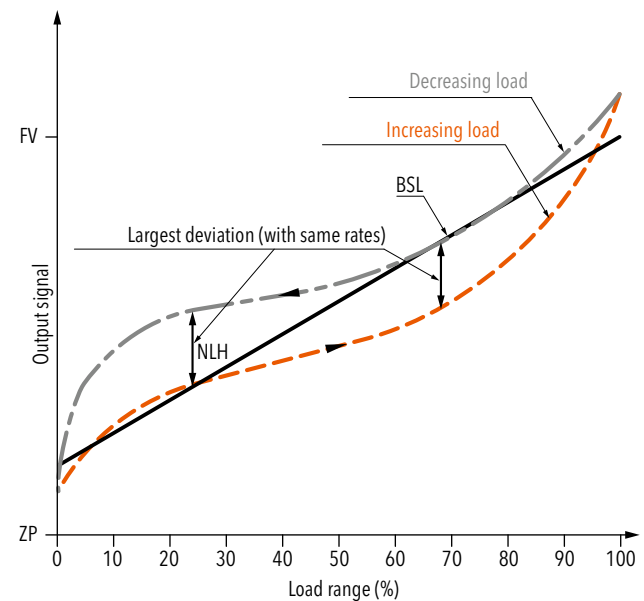

Terminology for pressure measurement instruments

BSL through zero

As an additional requirement for the minimum value adjustment, the BSL through zero (also BSL/0) must go straight through zero or the origin.

Specifications: Accuracy NLH (BSL through zero)

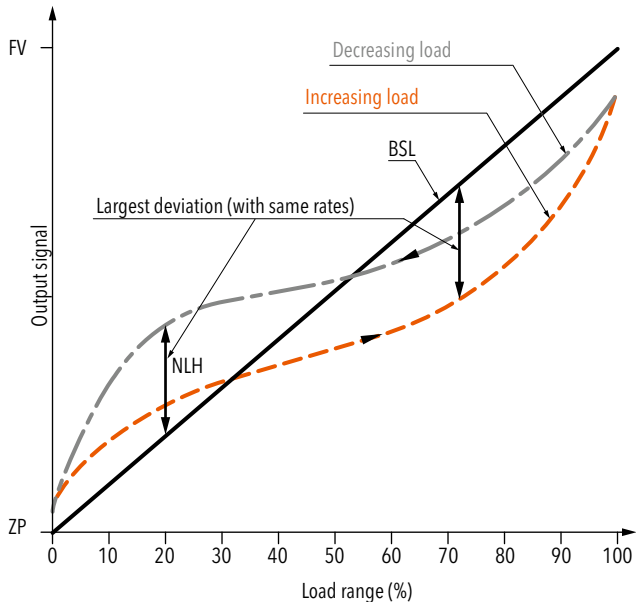

Non-linearity according to limit point adjustment

The reference line runs through the origin and end point of the characteristic line. Non-linearity indicates the greatest deviations from this line.

Hysteresis

Property of an instrument for yielding different output values in relation to its input values, which are dependent on the effective direction in which the input values are created (acc. to IEC 61298-2).

Pressure hysteresis

The difference that occurs at the same pressure between measurements in the direction of increasing and then decreasing pressure.

Temperature hysteresis

Maximum change of the zero point and output span for the pressure signal after specified temperature cycle over the operating temperature range.

NLH non-linearity and hysteresis

Largest deviation from the ideal characteristic line (BSL, BSL/0 or limit point). In pressure measuring instruments, the non-linearity and pressure hysteresis are given together at a constant temperature.

Accuracy DIN 16086: Measurement deviation

The accuracy denoted in the standard DIN 16086 with measurement deviation (at 25°C reference temperature) includes all deviations as a result of non-linearity, hysteresis, non-repeatability, zero point (start of measuring range) errors and span (end of measuring range) errors. Zero point errors and span errors also include the measuring uncertainty of the configuration ensemble.

Repeatability DIN 16086: Non-repeatability

Deviation of the output signals with same input signals under identical (established) application conditions.

Temperature coefficient TC

Change of measured value for zero point and span as a result of changes in temperature.

Long-term stability Long-term drift

The change of accuracy due to aging under certain reference conditions during a certain period of time, typically 1 year.

TEB Total error band

Total error (root from sum of the square of the deviations) due to measurement deviations (accuracy) and temperature influence (temperature coefficient TC). The temperature influence is usually given in the information from Trafag across a range larger than that given in the standard (-10 ... +60 °C). Whilst DIN 16086 also continues to add to the long-term stability over a year, the information from Trafag is subject to ex-works conditions for obvious reasons.

Scale accuracy

For pressostats: Deviation arising from the manual switch point adjustment with the help of the display (scale).

Electrical Data

Output signal

Electrical signal that emits the value of the measurement size for further processing

Rise time Step response

The time it takes for an output signal after a severe pressure change to increase from 10% to 90% of its final value that results from the change in pressure.

Zero point ZP

Output signal in the pressureless state (P_{\min}), e.g. 4 mA at 0 bar (P_{\min}).

Terminology for pressure measurement instruments

Final value FV

Output value of the largest pressure value in the nominal pressure range (P_{max}), e.g. 20 mA at 100 bar (P_{max}).

Span S

Final value (FV) - zero point (ZP) = span (S)

e.g. span (S) = (FV) 20 mA - (ZP) 4 mA = 16 mA

Switching differential Pressostats

Range within which the micro-switch in pressostats switches on and off

Example:

X...X = adjustable value

X - X = non-adjustable value; runs proportional to the nominal pressure

X = fixed value

Limiter Pressostats

Pressostat with manual micro-switch reset.

Environmental conditions

Media temperature

Permissible temperature range of the measuring media.

Operating temperature Ambient temperature

Temperature range in which the measuring instrument adheres to its specifications. As the electronics in certain instruments are more sensitive to temperature than the sensor element, the maximum ambient temperature for the instrument is lower than the permissible media temperature.

Storage temperature

Temperature range in which the measuring instrument can be stored or transported without permanently changing the measuring characteristics.

Protection

Humidity and dust shield according to IP classes in accordance with EN 60529.

EMC Protection

EMC Electromagnetic compatibility

Instrument property for functioning in an environment with electromagnetic interference and for not unduly influencing this environment (to which other equipment also belongs).

Immission

Immunity to external electromagnetic disturbances.

Emission

Interference emission from electromagnetic disturbances.

Surge

Immunity to unipolar surge voltages that can occur due to surges as a result of switching operation and lighting.

Burst

Immunity to recurring, rapid, transient electrical disturbances.

Information on Ex products

Trafag offers a wide range of EX-, ATEX- and IECEx approved products for pressure and temperature monitoring. These products provide reliable functionality in various hazardous zones, with a guaranteed safety operation. In addition to both CE and ATEX-conformance, Trafag products are also extremely fail-safe.

CE - Designation and labelling

CE 1258 **Ex** **II 2 GD**

Control No. of notified body for the supervision of the quality assurance system

I: Mining
II: All other applications

Category (see below)

G = Gas
D = Dust

- Category 1: Can be used in zone 0 (gas) and 20 (dust)
 - Potentially explosive atmosphere: Permanent
 - Two independent failures - safety
- Category 2: Can be used in zone 1 (gas) and 21 (dust)
 - Potentially explosive atmosphere: Regularly
 - One failure - safety
- Category 3: Can be used in zone 2 (gas) and 22 (dust)
 - Potentially explosive atmosphere: Unlikely or for very short time

IEC/EN 60079-8 - Gases

Ex ia IIC T6 Ga

Type of protection

Equipment groups (for gases)

Temperature class

Equipment protection level

- Type of protection: Intrinsically safe
- Equipment group (gases): IIC = Hydrogen, Acetylene
- Temperature level: Defines ignition temperature and permissible temperature of equipment surface
- Protection level: Referring to installation zone (Ga = Zone 0 = Category 1 in ATEX)

IEC/EN 60079-0 - Dust

Ex ia IIIC IP6X T130 °C Da

Type of protection

Equipment groups (for dust)

IP protection

Surface temperature

Equipment protection level

- Type of protection: Intrinsically safe, powder filling, encapsulation, ...
- Equipment group (dust): IIIC = Conductive dust
- Temperature level: Defines maximum surface temperature
- Protection level: Referring to installation zone (Da = Zone 20 = Category 1 in ATEX)

EN 50303 - Mining

Ex ia I Ma

Type of protection

Equipment for mining

Equipment protection level

- Category and Protection level:
 - Category M1 / Protection level Ma: Fully functional and safe when explosive atmosphere is present. Requires means to cope with two independent failures
 - Category M2 / Protection level Mb: These products are intended to be deenergised in the presence of an explosive atmosphere

Simple Apparatus

Pressostats and Thermostats, when combined with a certified switch amplifier (Zener barrier/Zener relay), can be used as «simple electrical apparatus» in Zone 1 and 2, as well as in Zone 21 and 22, according to EN 60079-11. These pressostats and thermostats are not suitable for Zone 0 and Zone 20. The use in safety relevant applications (approved electrical apparatus) is not permitted.

Switch amplifiers are suitable for intrinsically safe applications. The device transmits signals from the hazardous area into the safe area.

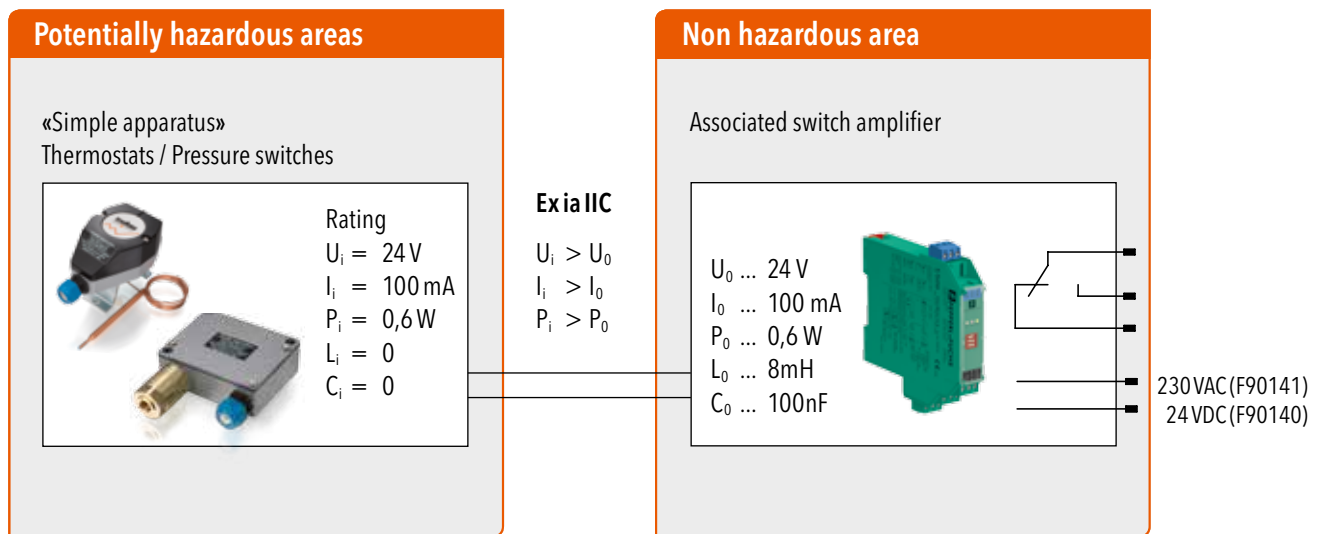

Recommended switch amplifier (see chapter “Accessories”):

Trafag parts no.: ZEN230VAC (230 VAC)

ZEN24VDC (24 VDC)

If another type of switch amplifier is used, make sure its electrical rating limits are within the specification of the simple apparatus thermostat or pressostat.

Conversion of pressure units

	bar	mbar	Pa N/m ²	kPa kN/m ²	MPa MN/m ²	at kp/cm ²	atm	mmWS mmCE	mWS mCE	Torr mm Hg	psi lbf/in ²
1 bar	1	1000	10 ⁵	100	0.1	1.02	0.987	1.02·10 ⁴	10.2	750	14.5
1 mbar	0.001	1	100	0.1	10 ⁻⁴	1.02·10 ⁻³	0.987·10 ⁻³	10.2	0.0102	0.75	0.0145
1 Pa 1 N/m²	10 ⁻⁵	0.01	1	0.001	10 ⁻⁶	1.02·10 ⁻⁵	0.987·10 ⁻⁵	0.102	1.02·10 ⁻⁴	0.0075	1.45·10 ⁻⁴
1 kPa 1 kN/m²	0.01	10	1000	1	0.001	0.0102	9.87·10 ⁻³	102	0.102	7.5	0.145
1 MPa 1 MN/m²	10	10 ⁴	10 ⁶	1000	1	10.2	9.87	1.02·10 ⁵	102	7500	145
1 at 1 kp/cm²	0.981	981	0.981·10 ⁵	98.1	0.0981	1	0.968	10 ⁴	10	736	14.22
1 atm	1.013	1013	1.013·10 ⁵	101.3	0.1013	1.033	1	1.033·10 ⁴	10.332	760	14.696
1 mmWS 1mmCE	0.981·10 ⁻⁴	0.098	9.807	9.81·10 ⁻³	9.81·10 ⁻⁶	10 ⁻⁴	0.968·10 ⁻⁴	1	0.001	0.0736	1.422·10 ⁻³
1 mWS 1mCE	0.0981	98.07	9807	9.81	9.81·10 ⁻³	0.1	0.0968	1000	1	73.6	1.422
1 Torr 1 mmHg	1.133·10 ⁻³	1.333	133.323	0.133	1.333·10 ⁻⁴	1.36·10 ⁻³	1.316·10 ⁻³	13.595	1.359·10 ⁻²	1	1.934·10 ⁻²
1 psi 1 lbf/in²	6.895·10 ⁻²	68.95	6895	6.895	6.895·10 ⁻³	7.031·10 ⁻²	0.06805	703.1	0.7031	51.7	1

Conversion of temperature units

[°F] to [°C] Formula: °C = 5/9·(°F - 32)					
°F	°C	°F	°C	°F	°C
-100	-73.3	105	40.6	315	157.2
-95	-70.6	110	43.3	320	160.0
-90	-67.8	115	46.1	325	162.8
-85	-65.0	120	48.9	330	165.6
-80	-62.2	125	51.7	335	168.3
-75	-59.4	130	54.4	340	171.1
-70	-56.7	135	57.2	345	173.9
-65	-53.9	140	60.0	350	176.7
-60	-51.1	145	62.8	355	179.4
-55	-48.3	150	65.6	360	182.2
-50	-45.6	155	68.3	365	185.0
-45	-42.8	160	71.1	370	187.8
-40	-40.0	165	73.9	375	190.6
-35	-37.2	170	76.7	380	193.3
-30	-34.4	175	79.4	385	196.1
-25	-31.7	180	82.2	390	198.9
-20	-28.9	185	85.0	395	201.7
-15	-26.1	190	87.8	400	204.4
-10	-23.3	195	90.6	405	207.2
-5	-20.6	200	93.3	410	210.0
0	-17.8	205	96.1	415	212.8
5	-15.0	210	98.9	420	215.6
10	-12.2	215	101.7	425	218.3
15	-9.4	220	104.4	430	221.1
20	-6.7	225	107.2	435	223.9
25	-3.9	230	110.0	440	226.7
30	-1.1	235	112.8	445	229.4
32	0	240	115.6	450	232.2
35	1.7	245	118.3	455	235.0
40	4.4	250	121.1	460	237.8
45	7.2	255	123.9	465	240.6
50	10.0	260	126.7	470	243.3
55	12.8	265	129.4	475	246.1
60	15.6	270	132.2	480	248.9
65	18.3	275	135.0	485	251.7
70	21.1	280	137.8	490	254.4
75	23.9	285	140.6	495	257.2
80	26.7	290	143.3	500	260.0
85	29.4	295	146.1	505	262.8
90	32.2	300	148.9	510	265.6
95	35.0	305	151.7	515	268.3
100	37.8	310	154.4	520	271.1

[°C] to [°F] Formula: °F = 9/5·(°C + 32)					
°C	°F	°C	°F	°C	°F
-100	-148	105	221	315	599
-95	-139	110	230	320	608
-90	-130	115	239	325	617
-85	-121	120	248	330	626
-80	-112	125	257	335	635
-75	-103	130	266	340	644
-70	-94	135	275	345	653
-65	-85	140	284	350	662
-60	-76	145	293	355	671
-55	-67	150	302	360	680
-50	-58	155	311	365	689
-45	-49	160	320	370	698
-40	-40	165	329	375	707
-35	-31	170	338	380	716
-30	-22	175	347	385	725
-25	-13	180	356	390	734
-20	-4	185	365	395	743
-15	5	190	374	400	752
-10	14	195	383	405	761
-5	23	200	392	410	770
0	32	205	401	415	779
5	41	210	410	420	788
10	50	215	419	425	797
15	59	220	428	430	806
20	68	225	437	435	815
25	77	230	446	440	824
30	86	235	455	445	833
32	89.6	240	464	450	842
35	95	245	473	455	851
40	104	250	482	460	860
45	113	255	491	465	869
50	122	260	500	470	878
55	131	265	509	475	887
60	140	270	518	480	896
65	149	275	527	485	905
70	158	280	536	490	914
75	167	285	545	495	923
80	176	290	554	500	932
85	185	295	563	505	941
90	194	300	572	510	950
95	203	305	581	515	959
100	212	310	590	520	968

Trafag international

Europe

■ Headquarters, Switzerland

Trafag AG
Industriestrasse 11
CH - 8608 Bubikon
Tel. +41 44 922 32 32
www.trafag.com
e-mail: trafag@trafag.com

■ Albania, Bosnia-Herzegovina, Macedonia, Montenegro, Serbia, Slovenia

Axo-Texcomp Services SA
P.O. Box 88
CH - 1164 Buchillon
Tel. +41 21 807 22 01
mbucher@axotex.ch

■ Austria

Trafag GmbH
Konrad-Doppelmayr-Strasse 17
AT - 6922 Wolfurt
Tel. +43 5574 20866
www.trafag.at
e-mail: trafagat@trafag.com

■ Belgium

Marktechnical B.V.B.A.
Boxtelstraat 11
BE - 2320 Hoogstraten
Tel. +32 3 311 8864
www.marktechnical.be
e-mail: info@marktechnical.be

■ Croatia

Albania, Bosnia-Herzegovina, Macedonia, Montenegro, Serbia, Slovenia

VARGA ELEKTRONIK d.o.o.
Draškovićeva 12
Draškovec
HR - 40323 Prelog
Tel. +385 40 643 189
www.varga-elektronik.hr
e-mail: info@varga-elektronik.hr

■ Cyprus

ACTech Ltd.
60 Mesologiu Str, 185-45
GR - Piraeus
Tel. +30 210 4630 825
www.actech.gr
e-mail: actech1@otenet.gr

■ Czech Republic

Trafag spol. s r.o.
Vilémovská 2129
CZ - 347 01 Tachov
Tel. +420 374 723 250
www.trafag.cz
e-mail: prodej@trafag.com

■ Denmark

OEM Automatic Klitsø A/S
Engholm Parkvej 4
DK - 3450 Allerød
Tel. +45 70 10 64 00
www.oemklitsø.dk
e-mail: info@oemklitsø.dk

■ Estonia, Latvia

Wermundsen OÜ
Pärnu mnt. 142
EE - 11317 Tallinn
Tel. +372 601 4202
www.wermundsen.ee
e-mail: wermundsen@wermundsen.ee

■ Finland

Wexon OY
Turvekuja 6
FI - 00700 Helsinki
Tel. +358 9 290 440
www.wexon.com
e-mail: wexon@wexon.fi

■ France

Trafag S.A.R.L.
2 Boulevard Westinghouse
FR - 93270 Sevran
Tel. +33 1 4863 0101
www.trafag.fr
e-mail: trafagfr@trafag.com

■ Germany

Trafag GmbH
Kelterstrasse 59
DE - 72669 Unterensingen
Tel. +49 7022 40590-0
www.trafag.de
e-mail: info@trafag.de

■ Great Britain

Trafag (UK) Ltd.
Units 12&14, Josselin Court,
Josselin Road
Burnt Mills Industrial Estate
GB - Basildon, Essex SS13 1QF
Tel. +44 1 268 727 172
www.trafag.co.uk
e-mail: enquiries@trafag.co.uk

■ Greece

ACTech Ltd.
60 Mesologiu Str, 185-45
GR - Piraeus
Tel. +30 210 4630 825
www.actech.gr
e-mail: actech1@otenet.gr

■ Hungary

OEM Automatic Kft.
Gyár u.2.
HU - 2040 Budaörs
Tel. +36 23 880 895
www.oemautomatic.hu
e-mail: info@oemautomatic.hu

■ Iceland

Samey ehf.
Lyngas 13
IS - 210 Gardabaer
Tel. +354 510 5200
www.samey.is
e-mail: sala@samey.is

■ Italy

Trafag Italia S.r.l.
c/o Tecnocity Altomilanese
Via Cremona, 1
IT - 20025 Legnano (MI)
Tel. +39 0 331 592 397
www.trafagitalia.com
e-mail: info@trafagitalia.com

■ Netherlands

Marktechnical B.V.
Lage Ham 172-178
P.O. Box 324 / 5100 AH Dongen
NL - 5102 AE Dongen
Tel. +31 162 31 42 85
www.marktechnical.nl
e-mail: info@marktechnical.nl

Trafag international

Europe

■ Norway

Stork AS
Brynsveien 100
NO - 1352 Kolsas
Tel. +47 67 17 64 00
www.stork.no
e-mail: stork@stork.no

■ Poland

POLTRAF Sp. z o. o.
ul. Bysewska 26C
PL - 80-298 Gdańsk
Tel. +48 58 557 52 07
Tel. +48 58 557 52 23
www.poltraf.com
e-mail: info@poltraf.com.pl

■ Portugal

Contimetra Instrumentos Industriais Lda.
Rua do Proletariado, 15-B
Portela de Carnaxide
PT - 2790-138 Carnaxide
Tel. +351 214 203 900
www.contimetra.com
e-mail: industria@contimetra.com

■ Romania

Synchro Comp s.r.l.
ID Sarbu street no. 13 Camin 3
RO - Craiova 200561 Dolj
Tel. +40 317 800 000
www.synchro.ro
e-mail: office@synchro.ro

■ Russia

POLTRAF CIS
Lyubotinsky pr. 5
RU - 196105 St.-Petersburg
Tel. +7 812 244 94 24
www.poltraf.ru
e-mail: info@poltraf.ru

■ Spain

Trafag España S.L.
Parque Tecnológico Bizkaia
Edificio 101 – E
ES - 48170 Zamudio (Bizkaia)
Tel. +34 94 641 40 63
www.trafag.es
e-mail: info@trafag.es

■ Sweden

Regal Components AB
Lefflersgatan 1
SE - 754 50 Uppsala
Tel. +46 18 657 000
www.regal.se
e-mail: info@regal.se

■ Switzerland

see 'Headquarters'
Tel. +41 44 922 32 32
www.trafag.com
e-mail: trafag@trafag.com

■ Turkey

Alfa Elektronik Sensor Sanayi Ve Ticaret A.S.
Tuzla Kimya Sanayicileri O.S.B
Melek Aras Bulvari No: 67
TR - 34956 Tuzla-ISTANBUL
Tel. +90 216 399 44 04
www.alfasanayi.com
www.trafag.com.tr
e-mail: info@alfasanayi.com

■ Ukraine

Soliton Ltd.
19, Akademika Tupoleva str
UA - 04128 Kiev
Tel. +38 (044) 223 9843
www.soliton.com.ua
e-mail: soliton@soliton.com.ua

Trafag international

Asia

China

Engines, Shipbuilding: Entire China

Marinequip China Co., Ltd.
Room 1306A, 13.F, Jiaxing Building
877 Dong Fang Road
CN - Shanghai 200122
Tel. +86 21 6445 2545
e-mail: xuzhun@marinequip.com.cn

Engines:

Entire China
Shanghai SKY Trading Co., Ltd.
Bond Shanghai Office
Rm. 24D, Unit.2,
No. 1251 Jiangnan Rd
CN - Shanghai 200060
Tel: +86 21 6276 1312
www.sky-trading.com.cn
e-mail: bondwu@sky-trading.com.cn

General Industry:

Entire China
Beijing Macrosense Co., Ltd
The 2nd Floor, Building 60, No. 2
Jingyuanbeijie,
Yizhuang Economic Development Zone,
Daxing District,
CN - Beijing 100176
Tel. +86 10 8260 1626/8260 1361
Mobile +86 1370 103 7546
www.bjhjd.com.cn
e-mail: wanggui@macrosense.cn

SF6 Gas Density Monitoring:

Entire China
ETIC Electrical Equipment Co., Ltd.
A610 Pioneering Square,
No. 48 Keji Road,
CN - Xi'an 710075
Tel. +86 29 8799 9981/2/3
www.etic.cn
e-mail: info@etic.cn

India

Trafag Controls India Pvt. Ltd.
Plot no-248, Sector-7
IMT Manesar
IN - Gurgaon-122050,
Haryana
Tel. +91 124 404 47 20
www.trafag.com
e-mail: trafagindia@trafag.com

Indonesia

Please contact our headquarters
Switzerland
Tel. +41 44 922 32 32
www.trafag.com
e-mail: trafag@trafag.com

Iran

Jannatpour & Sadeghzadeh Trading Group
No. 257 South Lalehzar Street
IR - Tehran
Tel. +98 21 3397 5059
www.persian-automation.com
e-mail: info@persian-automation.com

Israel

Timcon Technologies Systems Ltd
3, Josef Levi St.
Industrial Zone P.O.B. 1057
IL - Kiryat Bialik 27110
Tel. +972 4 8742605
www.timcon.co.il
e-mail: timcon@timcon.co.il

Japan

Trafag Japan Co., Ltd.
2-13-5 Shiba Daimon
Minato-ku
JP - Tokyo 105-0012
Tel. +81 3 6435 7506
www.trafag.jp
e-mail: trafagjapan@trafag.com

Korea

Hwajin Enterprise Co., Ltd.
25, Mieumsandan 2-ro
Gangseo-gu
KR - Busan (46748)
Tel. +82 51 831 9447
www.trafagkorea.com
e-mail: hwa-jin@hwa-jin.com

Malaysia

SENSING Process Instruments Sdn Bhd
30, Jalan 30/119A
Taman Taynton View, Cheras,
MY - 56000 Kuala Lumpur
Tel. +603 9235 1038
www.sensing.com.my
e-mail: info@sensing.com.my

Philippines

West Point Engineering Supplies
West Point Building, Bacood Street,
Barangay Patubig
Marilao Bulacan
Philippines 3019
Tel. +63 44 797 2524
www.westpointengineering.com.ph
sales@westpointengineering.com.ph

Singapore

General Industry:

IndCon Technology (S) Pte. Ltd.
Blk 2021 Bukit Batok St 23 #04-210
SG - Singapore 659526
Tel. +65 6908 4838
www.indcontech.com
e-mail: sales@indcontech.com

Singapore

Shipbuilding:

Bond Instrumentation (S) Pte. Ltd.
8 Gul Street 3
SG - Singapore 629265
Tel. +65 68 651 800
www.bond.com.sg
e-mail: bondsales@bond.com.sg

Taiwan

Daybreak International (Taiwan) Corp.
3 F, No.124, Chung-Cheng Road,
Shihlin 11145
TW - Taipei
Tel. +886 2 8866 1234
www.daybreak.com.tw
e-mail: day111@ms23.hinet.net

Thailand

Themtech Co., Ltd.
127 Soi Srimuang-Anusorn
Sutthisarnvinijai Rd., Dindaeng
TH - Bangkok 10400
Tel. +662 693 6629
www.primusthai.com
e-mail: sales@themtech.co.th

Trafag international

Asia

■ United Arab Emirates

Abdulla Bin Hamid Trading LLC
Po Box 30495
AE - Dubai
Tel. +971 4 2241464
www.accutech.ae
e-mail: sales@accutech.ae

■ Vietnam

GNN Co. Ltd
33 Hoa Hong 2, Ward 2
Nhu Nhuan Dist. HCMC
Tel. +84 8 3517 4923
www.gnnvietnam.com
e-mail: contact@gnnvietnam.com

America

■ USA

Trafag, Inc.
8848 Red Oak Boulevard, Ste. I
US - Charlotte, NC 28217
Tel. +1 704 343 6339
www.trafag.us
e-mail: salesus@trafag.com

■ Canada

Indumart Inc.
25 Denison Street
CA - Markham, L3R 1B5,
Ontario
Tel. +1 905 944 9998
www.indumart.com
e-mail: sales@indumart.com

South America

■ Brazil

G&M Comercio de Produtos Ltda.
Rua Senador Queiros, 165
BR - 09050-300 Santo Andre - São Paulo
Tel. +55 11 4425-4245
www.gmtestemedicao.com.br
e-mail: vendas@gmtestemedicao.com.br

Sense Eletrônica
Rua Tuiuti 1237
BR - 03081-012 Tatuapé São Paulo SP
Tel. +55 11 2145-0421
www.sense.com.br
www.trafag.com.br
e-mail: vendas@sense.com.br

■ Colombia

Surti Industria S.A.S
Carrera 33 No 38 A Sur 46
Envigado - Antioquia
Tel. +57 4 3 34 3283
www.surtiindustria.com.co
e-mail: surtiindustria@une.net.co

Africa

■ South Africa

ICS (Pty) Ltd.
Instrumentation & Control Systems
1 Claerhout Crescent
ZA - Sasolburg, 1947 RSA
Tel. +27 82 900 83 12
www.instcon.co.za
e-mail: info@instcon.co.za

Australia, Oceania

■ Australia

Dart Instruments Pty. Ltd.
250 Military Road
AU - Neutral Bay NSW 2089
Tel. +61 2 8456 7550
www.trafag.com.au
e-mail: sales@dartinstruments.com.au

■ New Zealand

Eurotec Limited
750C Great South Road
Penrose
P.O. Box 14543
NZ - Panmure Auckland
Tel. +64 9 579 1990
www.eurotec.co.nz
e-mail: sales@eurotec.co.nz

Reliable quality

Worldwide represented, globally trusted, Swiss based



■ Headquarters

Switzerland

■ Subsidiaries

Austria
Czech Republic
France
Germany
Great Britain
India
Italy
Japan
Poland (Joint Venture)
Russia (Joint Venture)
Spain
USA

■ Representatives

Australia
Belgium
Brazil
Canada
China
Colombia
Croatia
Cyprus
Denmark
Estonia, Latvia
Finland
Greece
Hungary
Iceland
Indonesia
Iran
Israel
Korea
Malaysia
Netherlands
New Zealand
Norway
Philippines
Portugal
Romania
Singapore
South Africa
Sweden
Taiwan
Thailand
Turkey
Ukraine
United Arab Emirates
Vietnam

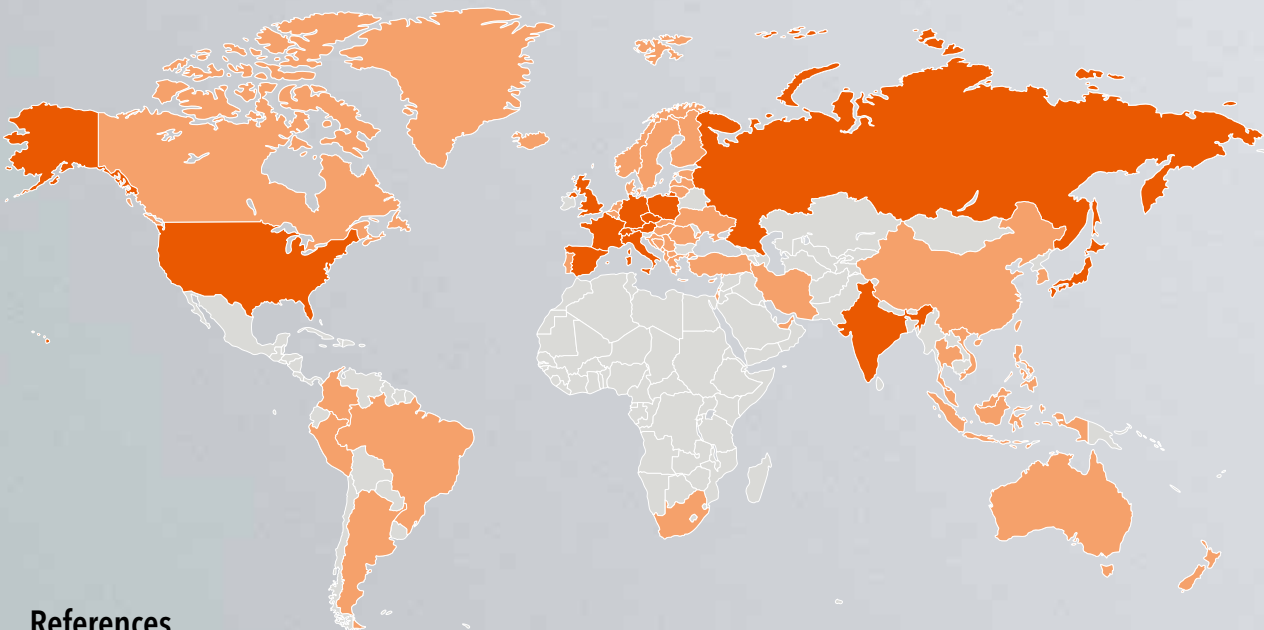

References

ABB | AIT | AGK | Alstom | Areva T&D | Atos | AVL | Benninghoven | Bharat Heavy Electrical | Blohm & Voss | Bombardier | Bosch Rexroth | BMW Rolls-Royce
Bühler | Caterpillar | Charmilles | Dalian Marine Diesel Ltd. | Detroit Diesel | Deutsche Bahn AG | Doosan Group | Dräger | Electrolux | Elektrobudowa S.A.
Faiveley | Fincantieri | Flender | Goninan | Greenfield | G&W | Hermetic Pumpen | Roche | Hudong Heavy Machinery | Hyundai Heavy Industries | IAV
Ingersoll Rand | Iveco | KOMA | MAN B&W | Melag | Mitsubishi | MTU | Noske-Kaaser | Oilon | Ormat Turbines | Parker | PESA | Philips | PKN Orlen S.A.
PMC | Polarteknik | Promeco | Queensland Rail | Reintjes | Renk | Rolls-Royce | Schindler | Schneider Electric | Schottel | Sciteq-Hammel | Siemens | SNCF
STX Heavy Industries | Thermax Limited | Toshiba | Trumpf | Verolme Shipyard | Vesta | Viessmann | Voith | Wärtsilä | Westfalia Separator | W&H
Yichang Marine Diesel Ltd | York | ZF Marine