

Compression load cell

Characteristics



- Stainless steel Armco
- Capacity 0 ... 1kN up to 0 ... 1000 kN
- Output strain gauge full bridge, 2 mV/V
- Protection IP 67
- Accuracy 0,1 % of end scale value
- Low height
- Connection: cable entry with 3 m cable (other connection optionally)
- Application of force with adaptor, optionally

Dimensions

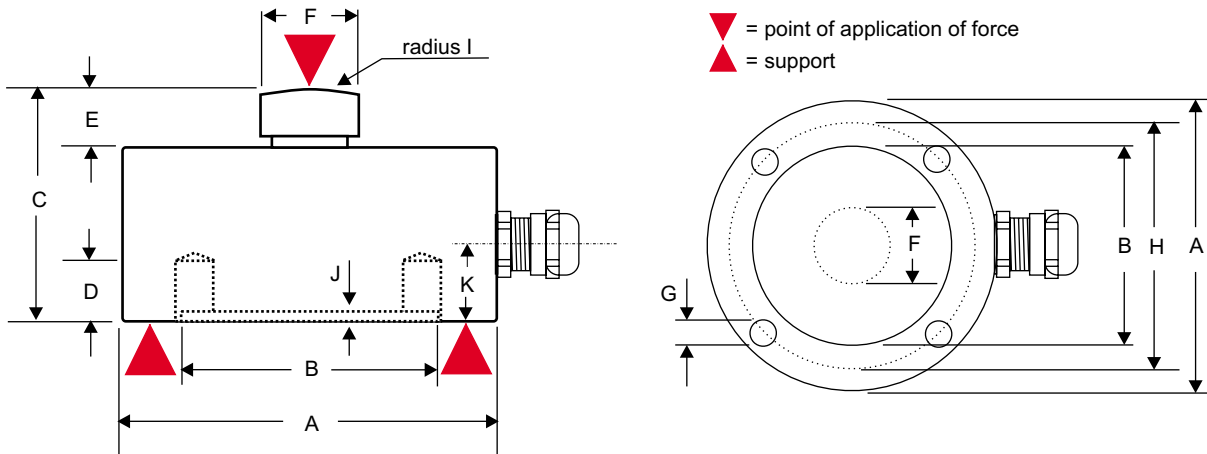

Capacity [kN]	ØA	ØB	C	D	E	ØF	G	ØH	I	J	K
1 / 2 / 5 / 10	49,5	34	30	8	7	13	M5	42	60	1,3	10
20 / 50	89,5	55	48	14	12,5	25	M10	70	100	2,5	17,5
100 / 200	115	68	60	16	12,5	32	M12	90	180	1,8	23
500 / 1000	150	97	80	20	15	44	M16	125	270	4,5	32

All dimensions in mm

Drilled holes G are turned by 90°

Applications

For use in all ranges where weights have to be measured, e.g. in electronic vehicle scales, in track scales, hoppers and silos in loading plants for ports and terotechnology.



