



## Vibrating fork level switch for liquids and solids

- Robust and compact
- Suitable for liquids (model LD61) and solids (model LD60)
- No moving parts, low maintenance
- Corrosion resistant materials
- Not affected by temperature or pressure changes
- Suitable for liquids with viscosity up to 10000 cSt
- Liquid density higher than 0.6 kg/l
- Solids: depending on application
- Detection length: up to 2 m
- Switching time: 1 s approx.
- Connections:
  - Threaded connections G1 or 1" NPT
  - Flanged connections DN40 PN25  
Other flange standards on request
  - Sanitary connections according to ISO 2852,  
SMS 1145, DIN 11851, TRI-CLAMP®
- Materials: EN 1.4404 (SS 316L). HALAR® coating on request
- Level detection, with LED status indication
- Options:
  - Relay output
  - NAMUR output Ex ia IIC T4 or T6



## Working principle

The LD series level switches are based on the variation of the natural resonant frequency of a vibrating fork when it comes into contact with a liquid or a solid.

This variation is detected by the internal electronics and is used to determine the state of the output.

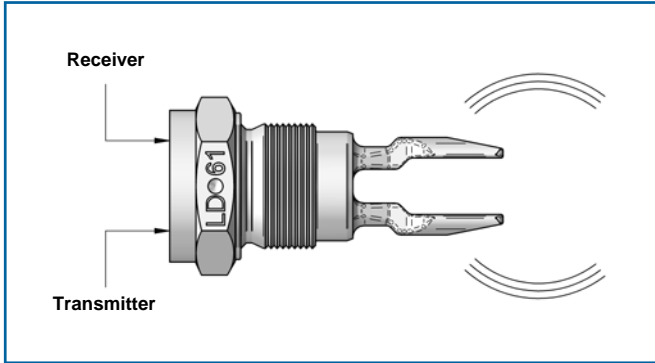

## Applications

- Pump control
- Open and pressurized tanks, tanks with agitation
- Open channel and empty / full pipe detection
- Distillation columns and evaporators
- Chemical dosing tanks

## Technical data

- Switching time: 1 s approx.
  - Hysteresis:  $\pm 2$  mm with H<sub>2</sub>O
  - Liquid density: higher than 0.6 kg/l
  - Liquid viscosity: up to 10000 cSt
  - Solids: depending on application. Consult factory
  - Detection length: up to 2 m
  - Fluid temperature: -30°C ... 115°C  
Ambient temperature: -20°C ... 70°C
  - Working pressure: PN25 (others on request)
  - Connections:
    - G1 or 1" NPT screwed connections
    - DN40 DIN 2501 (EN 1092-1) flanges
    - Sanitary connections according to ISO 2852, SMS 1145, DIN 11851, TRI-CLAMP®
- Others on request

## Models

- LD61: liquid level detection
- LD60: solid level detection
- LD6XN: liquid or solid level detection, with NAMUR Ex output
- LD6XR: liquid or solid level detection, with relay output
- LD6XML: liquid or solid level detection, with enlarged detection length

## Materials

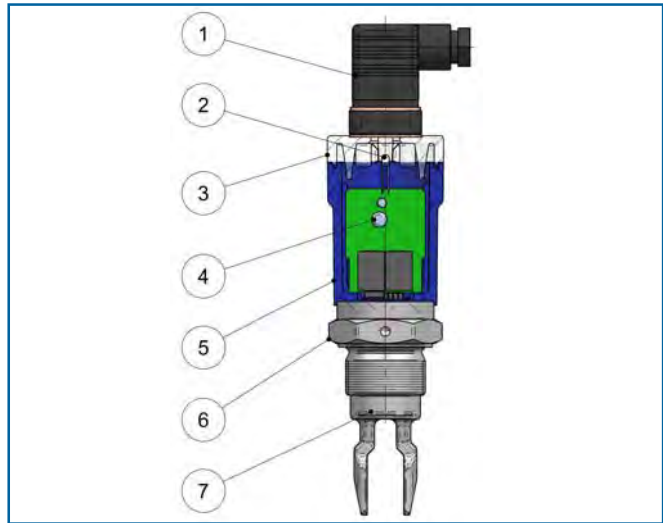

N°	Description	Materials
1	Connector / Housing	Polyamide
2	LED	Plastic
3	Cover	Polycarbonate
4	Electronics	-
5	Enclosure	Polycarbonate
6	Connection	EN 1.4404 (SS 316L) *
7	Body	EN 1.4404 (SS 316L) *

\* On request, with HALAR® coating

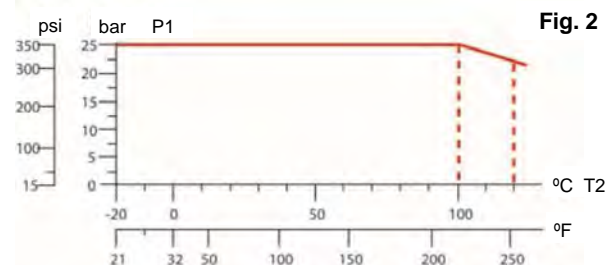
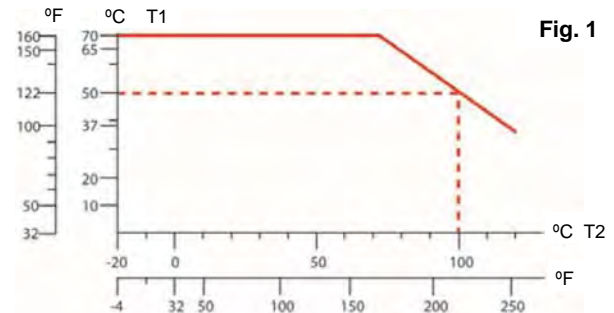

The maximum working temperature of the inside of the tank (T2) is a function of the ambient temperature on the outside (T1), as shown in Fig. 1.

The maximum working pressure in the tank is a function of the interior temperature, as shown in Fig. 2.

## Dimensions

**LD60 / LD61 - BSP / NPT threaded connection**

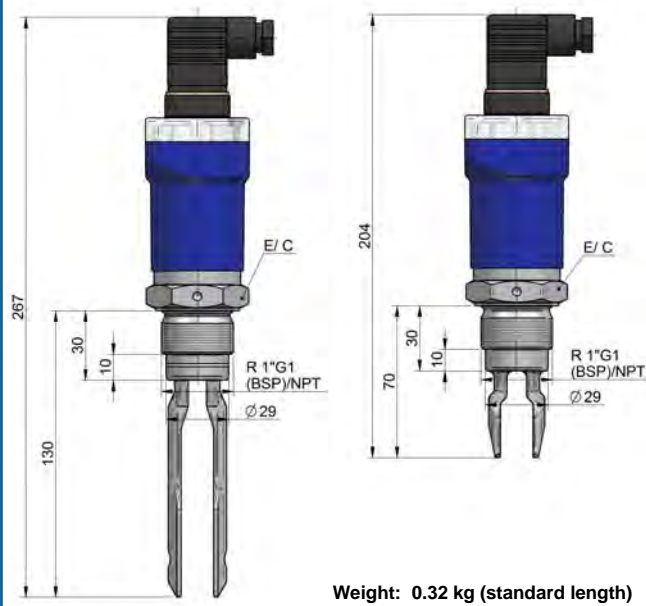

**LD60 / LD61 - TF DIN405 flush mounting**

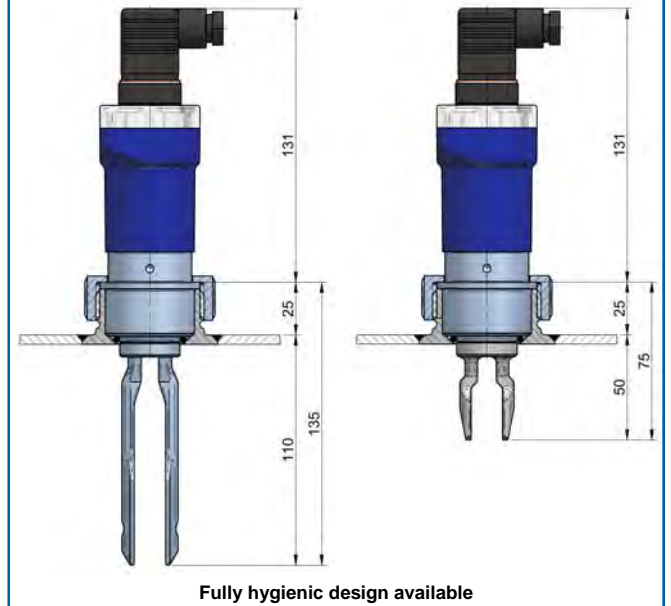

**LD60ML / LD61ML - special length**

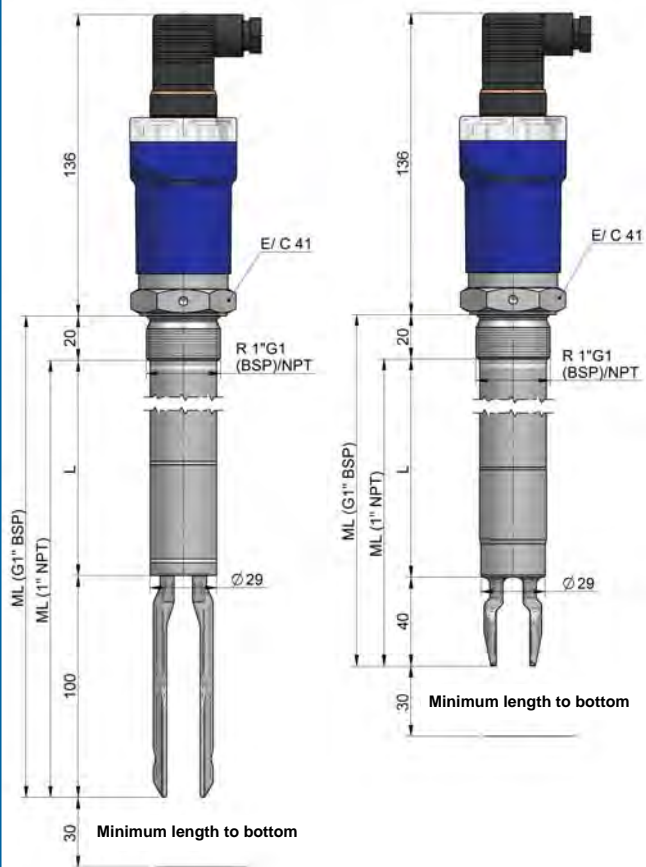

**LD60 / LD61 - CLAMP ISO 2852 connection**

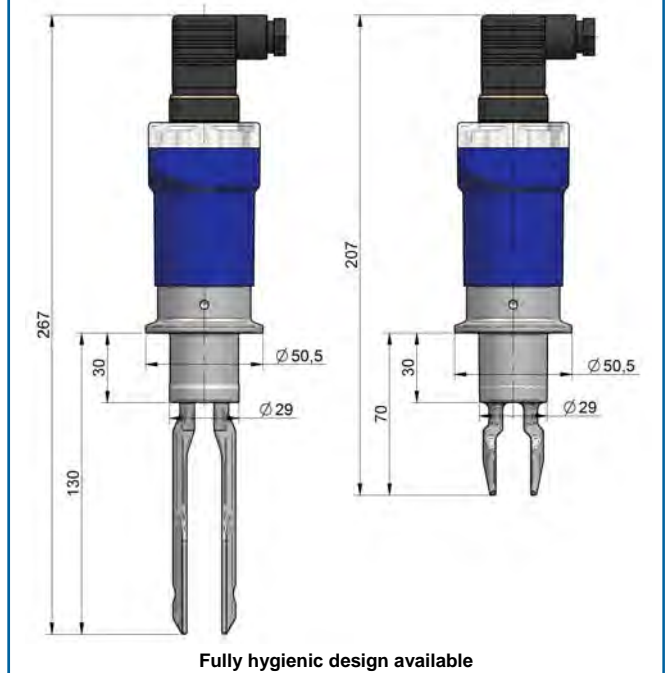

**All dimensions in mm**

Other sanitary couplings available on request.  
Fully hygienic design available for all the models with sanitary couplings.

**LD60ML / LD61ML (standard length ±1.5 mm)**

ML (G1)	260	360	560	860	1060	1260	1560	2060
ML (1" NPT)	240	340	540	840	1040	1240	1540	2040

### Model LD60 ... LD61

- Power supply:
  - 2 wires: 24 ... 250 VAC. Max. load 350 mA
  - 3 wires: 12 ... 55 VDC. Max. load 350 mA
 Min. load: 6 mA
- Outputs: PNP transistor for DC power supply; tiristor for AC power supply
- Status indication by means of bicolour LED
- Housing: IP65 DIN 43650-A connector, PG9 cable gland

### Model LD60R ... LD61R

- Power supply:
  - 25 ... 250 VAC / VDC
  - Consumption:  $\leq 1$  W
- Relay status indication by means of bicolour LED
- Housing: IP67 polycarbonate, PG11 cable gland  
Ex d IIC T6 on request, pending of certification
- Ambient temperature:  $-5^{\circ}\text{C} \dots +40^{\circ}\text{C}$

#### Relay characteristics

Number of contacts and type: double pole, double throw  
 Maximum switching current: 3 A  
 Maximum switching voltage: 220 VDC, 250 VAC  
 Maximum switching power: 60 W, 125 VA  
 Mechanical resistance:  $15.0 \times 10^6$  operations

### Model LD60N ... LD61N



- NAMUR (IEC60947-5-6, EN50227) switch
- Power supply:
  - 8 ... 14 VDC
  - Consumption: from 0.7 mA to 2.3 mA, depending on the status "ON/OFF"
- Status indication by means of LED
- Housing: IP65 DIN 43650-A connector, PG9 cable gland
- ATEX certification Ex ia IIC T4 (T6 on request)

#### Safety characteristics

Given that this instrument is group II, it is intended for use in places likely to become endangered by explosive atmospheres, but not in mines.

The category is 1G, that is, it is intended for use in areas in which explosive atmospheres caused by mixtures of air and gases, vapours or mists are present continuously, for long periods or frequently.

Marking	Ex ia IIC T4	Ex ia IIC T6
Specific parameters	$U_i = 14$ V $P_i = 1.3$ W	$U_i = 14$ V $P_i = 1.3$ W
Ambient temperature	$-5^{\circ}\text{C} \dots +40^{\circ}\text{C}$	

#### Dimensions for LD60R ... LD61R housing

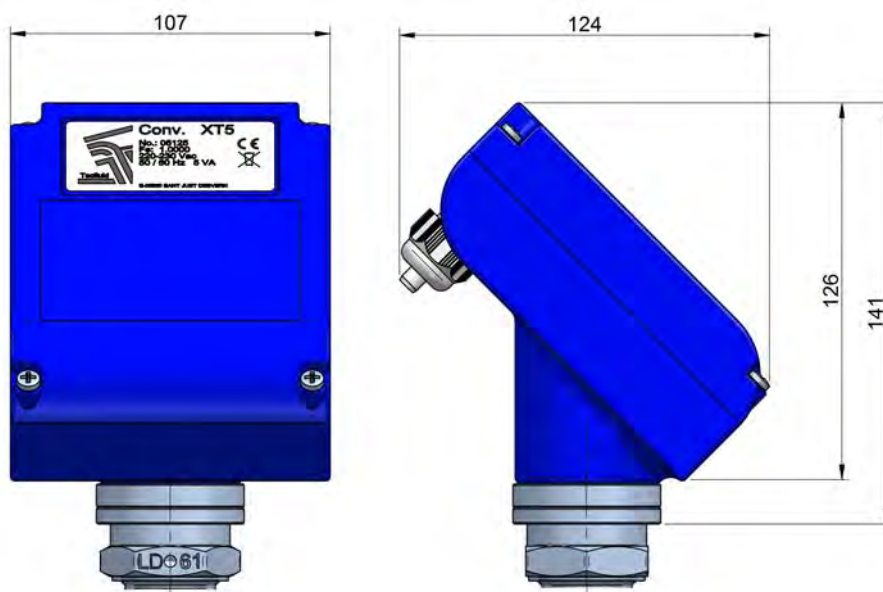

For fork dimensions, please consult p. 3

## Mounting

The optimal mounting position depends on the liquid viscosity. Both top of the tank (fig. 3a) and side (fig. 3b) mounting are optimal. In both positions the liquid can flow easily through the fork allowing correct detection of the liquid level.

### Connection size

In case of a small connection (smaller than DN50) the fork must be completely outside the neck of the coupling (fig. 4a) in order to make sure that particles inside the neck will not affect the level switch performance.

In cases with big connection sizes (bigger than DN50), the fork can be mounted inside the neck of the coupling, but only when the liquid viscosity allows it to flow out fast (fig. 4b).

### Viscous liquids

A minimum distance that ensures a fast flow of the liquid to free the fork is required (fig. 5a & 5b):  $D_{\text{minimum}} = 50 \text{ mm}$  (2")

### Detection of liquid in pipes

- Partially full horizontal pipes: the detector length must be carefully chosen so that forks are wetted by the liquid (fig. 6a).

- Control of liquid presence in pipes, for example in pump protection: the detector should be mounted in a vertical section with rising flow (fig. 6b). The switch length must be chosen carefully in order to avoid contact with the pipe.

The minimum recommended pipe size is DN50 (fig. 6c).

The maximum recommended flow speed is 5 m/s for liquids of  $1 \text{ g/cm}^3$  and  $1 \text{ mPa}\cdot\text{s}$  (please consult for other working conditions). For this application, the forks must be aligned with the pipe axis.

### High temperature applications

High temperatures in the tank may require thermal insulation. The LD can be supplied with required extra length. The standard extra length is 150 mm (fig. 7).

### Filling tanks

The mounting position of the level detector should not coincide with the point at which liquid falls inside the tank (fig. 8). If during the filling of the tank strong waves are produced, the level detector must be protected.

### Trucks

When controlling level in moving tanks, a guide pipe should be mounted, with a PTFE pushing at the lower end to avoid vibrations that could affect the level detector (fig. 9).

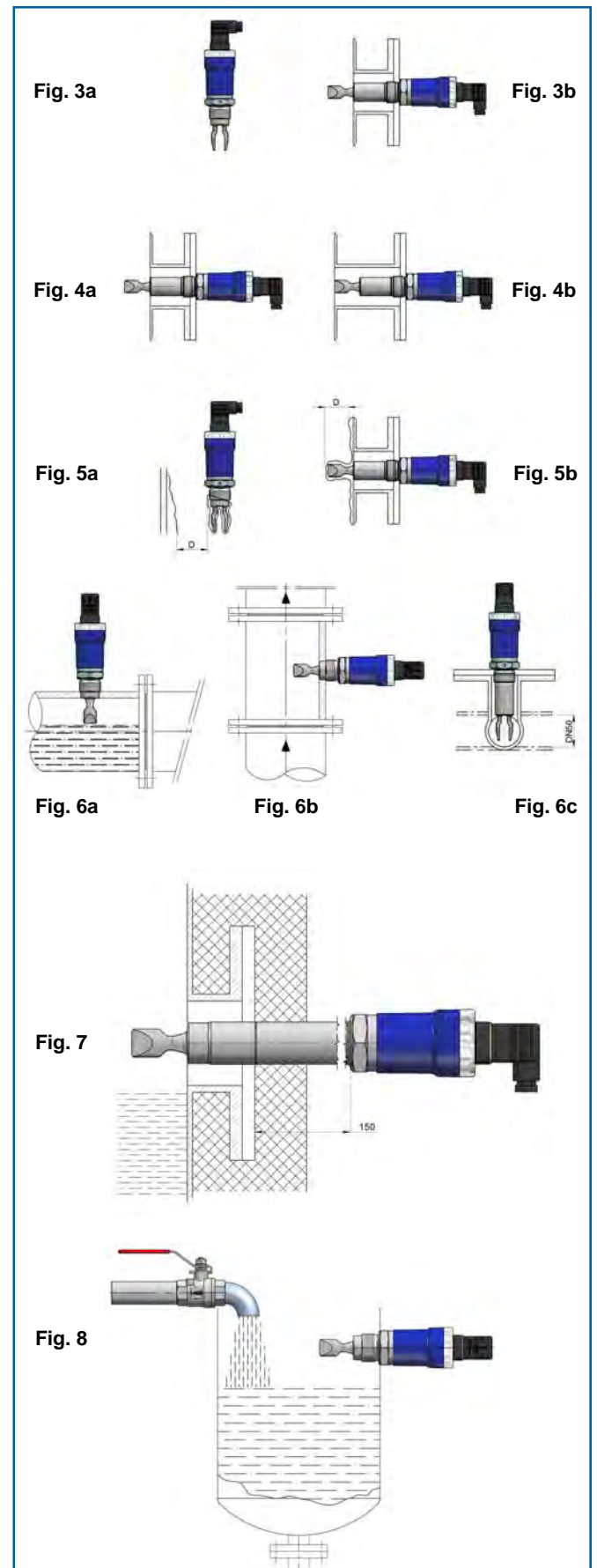
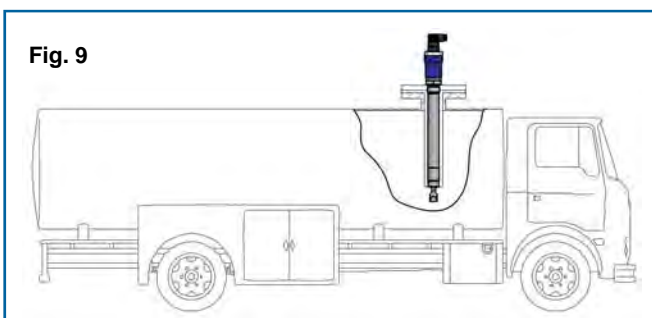

### Control of tanks and tanks with agitation

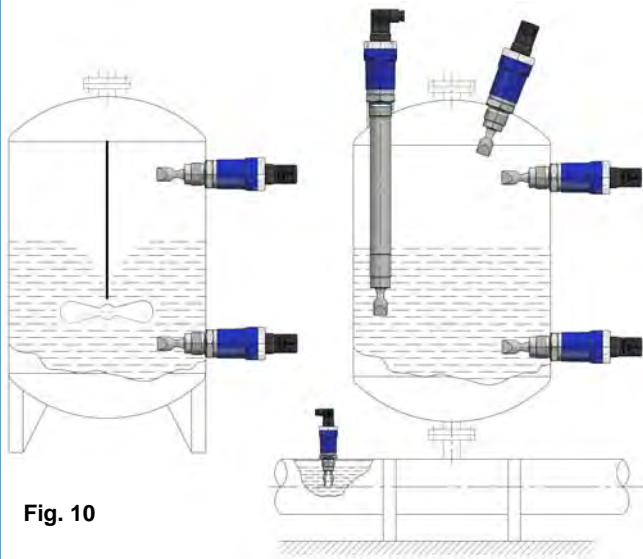

Fig. 10

In tanks with agitators, the LD61ML detector must be protected against the force of the rotating liquid in their whole length.

### Dosing tanks

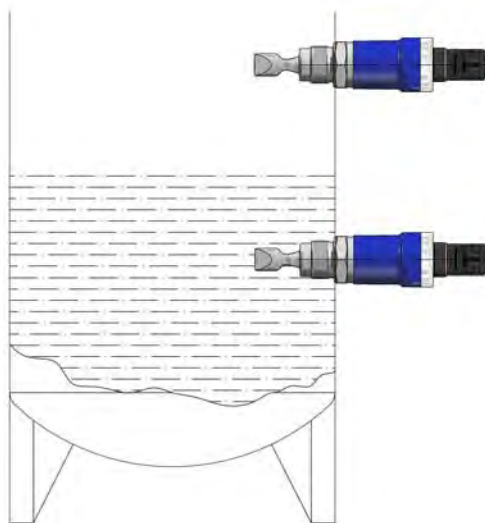

Fig. 11

### Accessories

The LD series can be supplied with a sliding system to adjust the height of the different maximum or minimum detection points that may be required in different processes in closed tanks.

The stuffing box supplied is fitted with a PTFE gland.

### Example

The level differential  $C$  between maximum and minimum = 100 mm. In this case length  $L1$  (300 mm) is the minimum level. The length  $LS$  is the maximum level (200 mm).

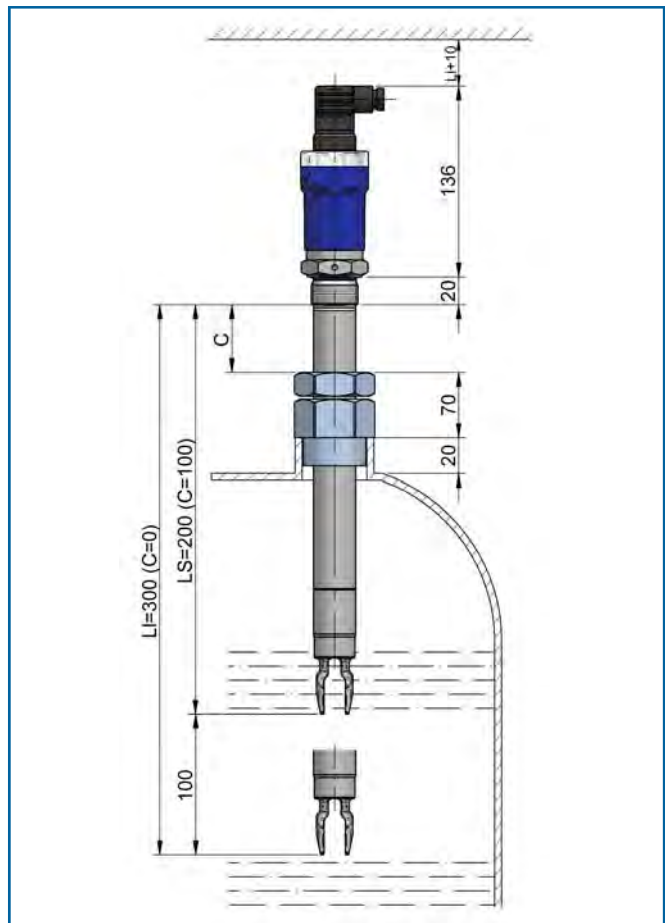

Quality Assurance System ISO 9001 certified by **Applus<sup>®</sup>**  
 Pressure Equipment Directive 97/23/CE certified by **Lloyds Register**  
 ATEX Directive 94/9/CE certified by **LOM**

TECFLUID, S.A. design and manufacture instrumentation for flow and level measurement using the most advanced techniques. May you need more information, please contact us.



Instrumentation for fluids

Narcis Monturiol 33 - 08960 Sant Just Desvern (Barcelona)  
 Tel.: (+34) 93 3724511 - Fax: 93 4730854 - Fax intl.: +34 93 4734449  
 www.tecfluid.com - e-mail: tecfluid@tecfluid.com